



Snake Trunk

12 C30 - E3

Ch. count
8, 12, 16,
24, 32

Cable length
C10=10m
C30=30m
C50=50m

Type of multichannel cable
E3=L-4E3 series
M2=M202 series



Junction Box

12 J12 N 12 (F77)

Ch. count
8, 12, 16, 24, 32

Cannon connectors
B1=female only
B2=male only
J12=male, female, parallel wired

Multichannel connector format
1=female
2=male
12=female and male
Type of multichannel connectors
N=NK type, F=FK type
MS=MS type



Fantail

12 S2 N 1

Ch. count
8, 12, 16,
24, 32

Cannon connectors
S1=female
S2=male

Multichannel connector
1=female
2=male
Type of multichannel connectors
N=NK type
F=FK type
MS=MS type



Cable Reel Snake

12 R30 - E3 (F77)

Ch. count
8, 12, 16, 24,

Cable length
R30=30m
R50=50m

Type of cable
E3=L-4E3 series
•Panel contains both male and female XLR connectors parallel wired

System Example

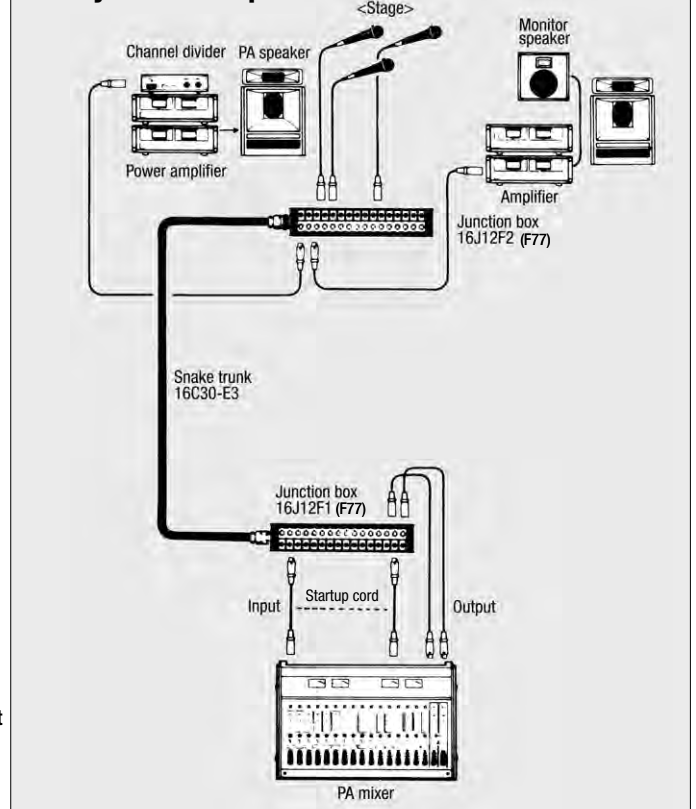

Connectors Used With Canare Multichannel Cable Systems

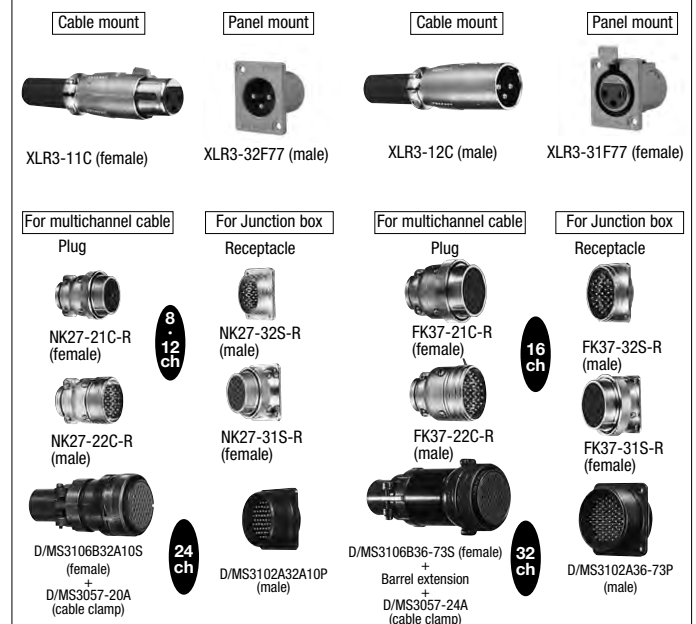

Multichannel Connector Pin Assignments

Ch No.	Cable Unit Identification		32ch		24ch		16ch		8ch · 12ch		
	L-4E3	M202	D/MS3102A36-73 D/MS3106B36-73		D/MS3102A32A-10 D/MS3106B32A-10		FK37		NK27		
	Spiral Marker Color	Insulator Color Identifying Color · Common Identifying Color	HOT	COLD	HOT	COLD	HOT	COLD	HOT	COLD	
1	RED	RED · WHT	A	B	A	B	1	2	1	3	
2	BLU	BLU ·	C	D	C	D	3	4	4	5	
3	YEL	YEL ·	F	H	F	G	5	6	6	7	
4	GRN	GRN ·	J	K	H	J	8	9	8	9	
5	BRN	BRN ·	L	M	K	L	10	11	11	12	
6	N/A	GRY ·	N	P	N	O	12	13	13	14	
7	BLU · BLK	BLU · BLK	R	S	P	R	14	15	15	16	
8	YEL · BLK	YEL ·	T	U	S	T	16	17	17	18	
9	GRN · BLK	GRN ·	V	W	U	V	21	22	19	20	
10	BRN · BLK	BRN ·	Y	Z	X	Y	23	24	22	23	
11	BLK	GRY ·	a	b	Z	a	25	26	24	25	
12	BLU · ORN	BLU · ORN	c	d	b	c	27	28	26	27	
13	YEL · ORN	YEL ·	f	g	d	e	29	30	SHIELD		
14	GRN · ORN	GRN ·	h	i	g	h	32	33	10		
15	BRN · ORN	BRN ·	j	k	j	k	34	35			
16	ORN	GRY ·	m	n	m	n	36	37			
17	BLU · PNK	BLU · PNK	u	v	p	q	SHIELD				
18	YEL · PNK	YEL ·	w	x	s	t	19				
19	GRN · PNK	GRN ·	y	z	u	v					
20	BRN · PNK	BRN ·	AA	AB	w	x					
21	PNK	GRY ·	AC	AD	AB	z					
22	BLU · WHT	BLU · RED	AE	AF	AA	AC					
23	YEL · WHT	YEL ·	AH	AJ	AD	AF					
24	GRN · WHT	GRN ·	AL	AM	AG	AE					
25	-	BRN ·	AN	AP	SHIELD						
26	-	GRY ·	AR	AS	E						
27	-	YEL · BLU	AT	AU							
28	-	GRN ·	AV	AW							
29	-	BRN ·	AX	AY							
30	-	GRN · YEL	AZ	BA							
31	-	BRN ·	BC	BD							
32	-	GRY ·	BE	BF							
			SHIELD								
			E	q	t						
			X	r	AK						
			p	s	BB						

32ch

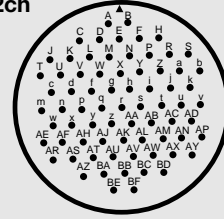

24ch

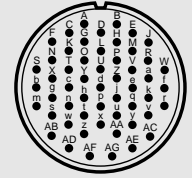

16ch

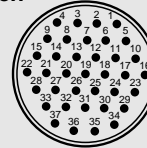

8 · 12ch

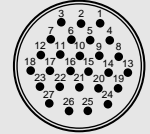

■ Connection Method

L-4E3 Types:

Identify the channel number by the color of the spiral marker on the inner jacket (gray). The unit is 4-core construction and the insulator colors are blue, blue, white, and white. Connect these with the same colored cores, so that the blue cores are connected to Hot and the white cores to Cold.

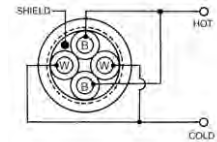





M202 Types:

The unit is 2-core construction, with the channel number identified by the insulator color (a combination of the identifying color and common identifying color). Connect the identifying color core to Hot, and the common identifying color core to Cold.

■ Connections to XLR Connectors

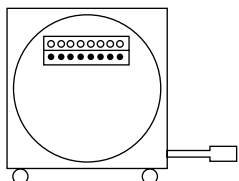
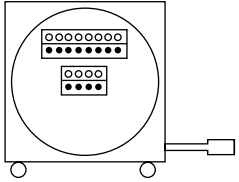
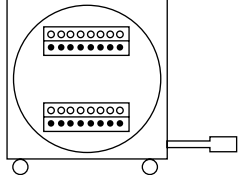
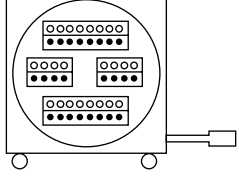
Polarity	HOT	COLD	SHIELD
Pin No.	2	3	1

	Snake Trunks		Cable Reel Snakes																																									
8 CH	<p>L-4E3 Star quad, Braided shield</p>  <p>connector : NK27-21C 3/4-R, NK27-22C 3/4-R cable : L-4E3-8P (black) rubber bushing : AN3420-12 + Heat Shrink Tube</p> <table border="1"> <thead> <tr> <th>Model</th> <th>Length</th> <th>Weight</th> </tr> </thead> <tbody> <tr> <td>8C05-E3</td> <td>5m</td> <td>1.6kg</td> </tr> <tr> <td>8C10-E3</td> <td>10m</td> <td>3.0kg</td> </tr> <tr> <td>8C30-E3</td> <td>30m</td> <td>8.4kg</td> </tr> <tr> <td>8C50-E3</td> <td>50m</td> <td>13.8kg</td> </tr> </tbody> </table>	Model	Length	Weight	8C05-E3	5m	1.6kg	8C10-E3	10m	3.0kg	8C30-E3	30m	8.4kg	8C50-E3	50m	13.8kg	<p>M2 Two-cord, AT shield</p>  <p>connector : NK27-21C 3/4-R, NK27-22C 3/4-R cable : M202-8AT (black) rubber bushing : AN3420-10, 12 + Heat Shrink Tube</p> <table border="1"> <thead> <tr> <th>Model</th> <th>Length</th> <th>Weight</th> </tr> </thead> <tbody> <tr> <td>8C10-M2</td> <td>10m</td> <td>1.7kg</td> </tr> <tr> <td>8C30-M2</td> <td>30m</td> <td>4.5kg</td> </tr> <tr> <td>8C50-M2</td> <td>50m</td> <td>7.3kg</td> </tr> </tbody> </table>	Model	Length	Weight	8C10-M2	10m	1.7kg	8C30-M2	30m	4.5kg	8C50-M2	50m	7.3kg	 <p>connector : NK27-21C-3/4-R cable : L-4E3-8P (black)</p> <table border="1"> <thead> <tr> <th>Model</th> <th>Length</th> <th>Weight</th> <th>Cable reel</th> </tr> </thead> <tbody> <tr> <td>8R30-E3 (F77)</td> <td>30m</td> <td>18.1kg</td> <td>R380</td> </tr> <tr> <td>8R50-E3 (F77)</td> <td>50m</td> <td>23.0kg</td> <td>R380</td> </tr> </tbody> </table>	Model	Length	Weight	Cable reel	8R30-E3 (F77)	30m	18.1kg	R380	8R50-E3 (F77)	50m	23.0kg	R380		
	Model	Length	Weight																																									
8C05-E3	5m	1.6kg																																										
8C10-E3	10m	3.0kg																																										
8C30-E3	30m	8.4kg																																										
8C50-E3	50m	13.8kg																																										
Model	Length	Weight																																										
8C10-M2	10m	1.7kg																																										
8C30-M2	30m	4.5kg																																										
8C50-M2	50m	7.3kg																																										
Model	Length	Weight	Cable reel																																									
8R30-E3 (F77)	30m	18.1kg	R380																																									
8R50-E3 (F77)	50m	23.0kg	R380																																									
12 CH	<p>connector : NK27-21C 7/8-R, NK27-22C 7/8-R cable : L-4E3-12P (black) rubber bushing : AN3420-16</p> <table border="1"> <thead> <tr> <th>Model</th> <th>Length</th> <th>Weight</th> </tr> </thead> <tbody> <tr> <td>12C05-E3</td> <td>5m</td> <td>2.1kg</td> </tr> <tr> <td>12C10-E3</td> <td>10m</td> <td>3.9kg</td> </tr> <tr> <td>12C30-E3</td> <td>30m</td> <td>11.1kg</td> </tr> <tr> <td>12C50-E3</td> <td>50m</td> <td>18.3kg</td> </tr> </tbody> </table>	Model	Length	Weight	12C05-E3	5m	2.1kg	12C10-E3	10m	3.9kg	12C30-E3	30m	11.1kg	12C50-E3	50m	18.3kg	<p>connector : NK27-21C 3/4-R, NK27-22C 3/4-R cable : M202-12AT (black) rubber bushing : AN3420-10, 12 + Heat Shrink Tube</p> <table border="1"> <thead> <tr> <th>Model</th> <th>Length</th> <th>Weight</th> </tr> </thead> <tbody> <tr> <td>12C10-M2</td> <td>10m</td> <td>2.1kg</td> </tr> <tr> <td>12C30-M2</td> <td>30m</td> <td>5.8kg</td> </tr> <tr> <td>12C50-M2</td> <td>50m</td> <td>9.3kg</td> </tr> </tbody> </table>	Model	Length	Weight	12C10-M2	10m	2.1kg	12C30-M2	30m	5.8kg	12C50-M2	50m	9.3kg	 <p>connector : NK27-21C-7/8-R cable : L-4E3-12P (black)</p> <table border="1"> <thead> <tr> <th>Model</th> <th>Length</th> <th>Weight</th> <th>Cable reel</th> </tr> </thead> <tbody> <tr> <td>12R30-E3 (F77)</td> <td>30m</td> <td>20.6kg</td> <td>R380</td> </tr> <tr> <td>12R50-E3 (F77)</td> <td>50m</td> <td>30.4kg</td> <td>R460</td> </tr> </tbody> </table>	Model	Length	Weight	Cable reel	12R30-E3 (F77)	30m	20.6kg	R380	12R50-E3 (F77)	50m	30.4kg	R460		
	Model	Length	Weight																																									
12C05-E3	5m	2.1kg																																										
12C10-E3	10m	3.9kg																																										
12C30-E3	30m	11.1kg																																										
12C50-E3	50m	18.3kg																																										
Model	Length	Weight																																										
12C10-M2	10m	2.1kg																																										
12C30-M2	30m	5.8kg																																										
12C50-M2	50m	9.3kg																																										
Model	Length	Weight	Cable reel																																									
12R30-E3 (F77)	30m	20.6kg	R380																																									
12R50-E3 (F77)	50m	30.4kg	R460																																									
16 CH	<p>connector : FK37-21C 7/8-R, FK37-22C 7/8-R cable : L-4E3-16P (black) rubber bushing : AN3420-16</p> <table border="1"> <thead> <tr> <th>Model</th> <th>Length</th> <th>Weight</th> </tr> </thead> <tbody> <tr> <td>16C05-E3</td> <td>5m</td> <td>2.6kg</td> </tr> <tr> <td>16C10-E3</td> <td>10m</td> <td>4.9kg</td> </tr> <tr> <td>16C30-E3</td> <td>30m</td> <td>14.1kg</td> </tr> <tr> <td>16C50-E3</td> <td>50m</td> <td>23.3kg</td> </tr> </tbody> </table>	Model	Length	Weight	16C05-E3	5m	2.6kg	16C10-E3	10m	4.9kg	16C30-E3	30m	14.1kg	16C50-E3	50m	23.3kg	<p>connector : FK37-21C 7/8-R, FK37-22C 7/8-R cable : M202-16AT (black) rubber bushing : AN3420-10, 12, 16</p> <table border="1"> <thead> <tr> <th>Model</th> <th>Length</th> <th>Weight</th> </tr> </thead> <tbody> <tr> <td>16C10-M2</td> <td>10m</td> <td>2.7kg</td> </tr> <tr> <td>16C30-M2</td> <td>30m</td> <td>7.5kg</td> </tr> <tr> <td>16C50-M2</td> <td>50m</td> <td>12.3kg</td> </tr> </tbody> </table>	Model	Length	Weight	16C10-M2	10m	2.7kg	16C30-M2	30m	7.5kg	16C50-M2	50m	12.3kg	 <p>connector : FK37-21C-7/8-R cable : L-4E3-16P (black)</p> <table border="1"> <thead> <tr> <th>Model</th> <th>Length</th> <th>Weight</th> <th>Cable reel</th> </tr> </thead> <tbody> <tr> <td>16R30-E3 (F77)</td> <td>30m</td> <td>24.1kg</td> <td>R380</td> </tr> <tr> <td>16R50-E3 (F77)</td> <td>50m</td> <td>36.1kg</td> <td>R460</td> </tr> </tbody> </table>	Model	Length	Weight	Cable reel	16R30-E3 (F77)	30m	24.1kg	R380	16R50-E3 (F77)	50m	36.1kg	R460		
	Model	Length	Weight																																									
16C05-E3	5m	2.6kg																																										
16C10-E3	10m	4.9kg																																										
16C30-E3	30m	14.1kg																																										
16C50-E3	50m	23.3kg																																										
Model	Length	Weight																																										
16C10-M2	10m	2.7kg																																										
16C30-M2	30m	7.5kg																																										
16C50-M2	50m	12.3kg																																										
Model	Length	Weight	Cable reel																																									
16R30-E3 (F77)	30m	24.1kg	R380																																									
16R50-E3 (F77)	50m	36.1kg	R460																																									
24 CH	<p>connector : D/MS3106B-32A10S+D/MS3057-20A x2 cable : L-4E3-24P (black) rubber bushing : AN3420-20</p> <table border="1"> <thead> <tr> <th>Model</th> <th>Length</th> <th>Weight</th> </tr> </thead> <tbody> <tr> <td>24C05-E3</td> <td>5m</td> <td>4.3kg</td> </tr> <tr> <td>24C10-E3</td> <td>10m</td> <td>7.7kg</td> </tr> <tr> <td>24C30-E3</td> <td>30m</td> <td>21.7kg</td> </tr> <tr> <td>24C50-E3</td> <td>50m</td> <td>35.7kg</td> </tr> </tbody> </table> <p>Extension Cord : D/MS3101A32A10P+D/MS3057-20A X 2 Cable : L-4E3-24P (black)</p> <table border="1"> <thead> <tr> <th>Model</th> <th>Length</th> <th>Weight</th> </tr> </thead> <tbody> <tr> <td>24C005-E3MS22</td> <td></td> <td></td> </tr> </tbody> </table>	Model	Length	Weight	24C05-E3	5m	4.3kg	24C10-E3	10m	7.7kg	24C30-E3	30m	21.7kg	24C50-E3	50m	35.7kg	Model	Length	Weight	24C005-E3MS22			<p>connector : D/MS3106B-32A10S+D/MS3057-20A x2 cable : M202-24AT (black) rubber bushing : AN3420-16, 20 + Heat Shrink Tube</p> <table border="1"> <thead> <tr> <th>Model</th> <th>Length</th> <th>Weight</th> </tr> </thead> <tbody> <tr> <td>24C10-M2</td> <td>10m</td> <td>4.0kg</td> </tr> <tr> <td>24C30-M2</td> <td>30m</td> <td>10.4kg</td> </tr> <tr> <td>24C50-M2</td> <td>50m</td> <td>16.8kg</td> </tr> </tbody> </table>	Model	Length	Weight	24C10-M2	10m	4.0kg	24C30-M2	30m	10.4kg	24C50-M2	50m	16.8kg	 <p>connector : D/MS3106B-32A10S cable : L-4E3-24P (black)</p> <table border="1"> <thead> <tr> <th>Model</th> <th>Length</th> <th>Weight</th> <th>Cable reel</th> </tr> </thead> <tbody> <tr> <td>24R30-E3 (F77)</td> <td>30m</td> <td>34.6kg</td> <td>R460</td> </tr> </tbody> </table>	Model	Length	Weight	Cable reel	24R30-E3 (F77)	30m	34.6kg	R460
	Model	Length	Weight																																									
24C05-E3	5m	4.3kg																																										
24C10-E3	10m	7.7kg																																										
24C30-E3	30m	21.7kg																																										
24C50-E3	50m	35.7kg																																										
Model	Length	Weight																																										
24C005-E3MS22																																												
Model	Length	Weight																																										
24C10-M2	10m	4.0kg																																										
24C30-M2	30m	10.4kg																																										
24C50-M2	50m	16.8kg																																										
Model	Length	Weight	Cable reel																																									
24R30-E3 (F77)	30m	34.6kg	R460																																									
32 CH	<p>connector : D/MS3106B36-73S+D/MS3057-24A x2 cable : M202-32AT (black) rubber bushing : AN3420-16, 20, 24</p> <table border="1"> <thead> <tr> <th>Model</th> <th>Length</th> <th>Weight</th> </tr> </thead> <tbody> <tr> <td>32C10-M2</td> <td>10m</td> <td>4.8kg</td> </tr> <tr> <td>32C30-M2</td> <td>30m</td> <td>13.1kg</td> </tr> <tr> <td>32C50-M2</td> <td>50m</td> <td>21.0kg</td> </tr> </tbody> </table> <p>Extension Cord</p> <p>connector : D/MS3101A36-73P+D/MS3057-24A x2 cable : M202-32AT (black)</p> <table border="1"> <thead> <tr> <th>Model</th> <th>Length</th> <th>Weight</th> </tr> </thead> <tbody> <tr> <td>32C005-M2MS22</td> <td></td> <td></td> </tr> </tbody> </table>	Model	Length	Weight	32C10-M2	10m	4.8kg	32C30-M2	30m	13.1kg	32C50-M2	50m	21.0kg	Model	Length	Weight	32C005-M2MS22			<p>connector : D/MS3101A36-73P+D/MS3057-24A x2 cable : M202-32AT (black)</p>																								
	Model	Length	Weight																																									
32C10-M2	10m	4.8kg																																										
32C30-M2	30m	13.1kg																																										
32C50-M2	50m	21.0kg																																										
Model	Length	Weight																																										
32C005-M2MS22																																												

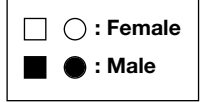

Note: Connecting cables 24C005-E3MS22 and 32C005-M2MS22 are to be used to interconnect snake trunks only and they do not mate with our other standard snake system. ★Production by order

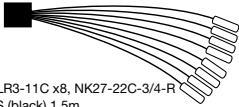
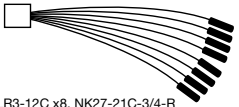
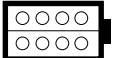
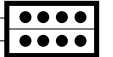
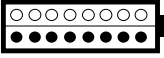
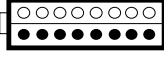
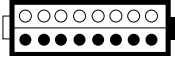
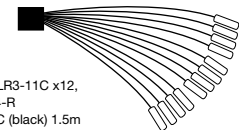
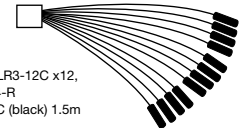
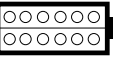
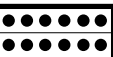
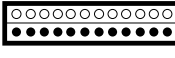
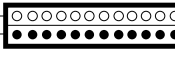
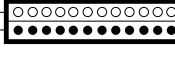
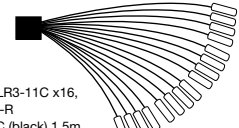
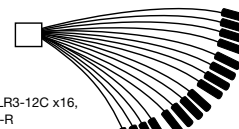
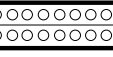
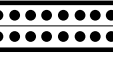
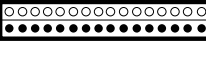
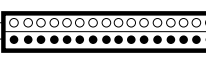
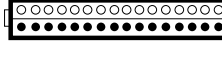
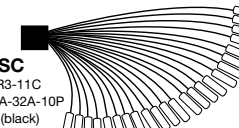
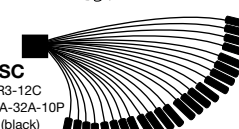
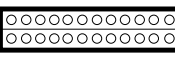
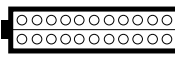
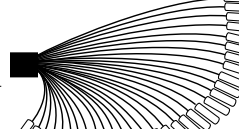
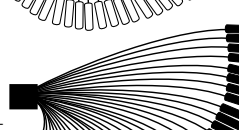
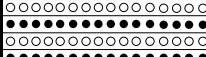
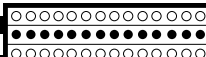
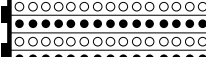
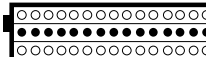
Fantails	Junction Boxes		
	Single XLR per channel	Parallel XLR per channel	Parallel XLR per channel MultiPin feed through
<p>8S1N2 Connector : XLR3-11C x8, NK27-22C-3/4-R Cable : L-4E6S (black) 1.5m Weight : 1.1kg</p>  <p>8S2N1 Connector : XLR3-12C x8, NK27-21C-3/4-R Cable : L-4E6S (black) 1.5m Weight : 1.0kg</p> 	<p>8B1N2(F77) Connector: XLR3-31F77 x8, NK27-32S-R x1 Weight : 0.9kg</p>  <p>8B2N1(F77) Connector: XLR3-32F77 x8, NK27-31S-R x1 Weight : 1.1kg</p> 	<p>8J12N2(F77) Connector: XLR3-31F77 x8, XLR3-32F77 x8 NK27-32S-R x1 Weight : 1.5kg</p>  <p>8J12N1(F77) Connector: XLR3-31F77 x8, XLR3-32F77 x8 NK27-31S-R x1 Weight : 1.5kg</p> 	<p>8J12N12(F77) Connector: XLR3-31F77 x8, XLR3-32F77 x8 NK27-31S-R x1, NK27-32S-R x1 Weight : 1.6kg</p> 
<p>12S1N2 Connector : XLR3-11C x12, NK27-22C-3/4-R Cable : L-4E5C (black) 1.5m Weight : 1.4kg</p>  <p>12S2N1 Connector : XLR3-12C x12, NK27-21C-3/4-R Cable : L-4E5C (black) 1.5m Weight : 1.3kg</p> 	<p>12B1N2(F77) Connector: XLR3-31F77 x12, NK27-32S-R x1 Weight : 1.3kg</p>  <p>12B2N1(F77) Connector: XLR3-32F77 x12, NK27-31S-R x1 Weight : 1.2kg</p> 	<p>12J12N2(F77) Connector: XLR3-31F77 x12, XLR3-32F77 x12 NK27-32S-R x1 Weight : 2.1kg</p>  <p>12J12N1(F77) Connector: XLR3-31F77 x12, XLR3-32F77 x12 NK27-31S-R x1 Weight : 2.1kg</p> 	<p>12J12N12(F77) Connector: XLR3-31F77 x12, XLR3-32F77 x12 NK27-31S-R x1, NK27-32S-R x1 Weight : 2.2kg</p> 
<p>16S1F2 Connector : XLR3-11C x16, FK37-22C-7/8-R Cable : L-4E5C (black) 1.5m Weight : 1.9kg</p>  <p>16S2F1 Connector : XLR3-12C x16, FK37-21C-7/8-R Cable : L-4E5C (black) 1.5m Weight : 1.7kg</p> 	<p>16B1F2(F77) Connector: XLR3-31F77 x16, FK37-32S-R x1 Weight : 1.6kg</p>  <p>16B2F1(F77) Connector: XLR3-32F77 x16, FK37-31S-R x1 Weight : 1.3kg</p> 	<p>16J12F2(F77) Connector: XLR3-31F77 x16, XLR3-32F77 x16 FK37-32S-R x1 Weight : 2.5kg</p>  <p>16J12F1(F77) Connector: XLR3-31F77 x16, XLR3-32F77 x16 FK37-31S-R x1 Weight : 2.5kg</p> 	<p>16J12F12(F77) Connector: XLR3-31F77 x16, XLR3-32F77 x16 FK37-31S-R x1, FK37-32S-R x1 Weight : 2.6kg</p> 
<p>24S1MS2-SC Connector : XLR3-11C x24, D/MS3101A-32A-10P Cable : L-4E5C (black) 1.5m</p>  <p>24S2MS2-SC Connector : XLR3-12C x24, D/MS3101A-32A-10P Cable : L-4E5C (black) 1.5m</p> 		<p>24B12MS(F77) Connector: XLR3-31F77 x24 (on top) XLR3-32F77 x24 (12 on each side) D/MS3102A-32A10P Weight : 2.7kg</p> 	<p>24B12MSW(F77) Connector: XLR3-31F77 x24 (on top) XLR3-32F77 x24 (12 on each side) D/MS3102A-32A10P x2 Weight : 3.0kg</p> 
<p>32S1MS2-SC Connector : XLR3-11C x32, D/MS3101A-36-73P Cable : L-4E5C (black) 1.5m</p>  <p>32S2MS2-SC Connector : XLR3-12C x32, D/MS3101A-36-73P Cable : L-4E5C (black) 1.5m</p> 		<p>32B12MS(F77) Connector: XLR3-31F77 x32, XLR3-32F77 x32 D/MS3102A36-73P Weight : 5.3kg</p>  <p>32B12MWF11(F77) Connector: XLR3-31F77 x32, XLR3-32F77 x32 D/MS3102A36-73P x2, FK37-31S-R x2 Weight : 6.0kg</p> 	<p>32B12MSW(F77) Connector: XLR3-31F77 x32, XLR3-32F77 x32 D/MS3102A36-73P x2 Weight : 5.5kg</p>  <p>32B12MF11(F77) Connector: XLR3-31F77 x32, XLR3-32F77 x32 D/MS3102A36-73P x1, FK37-31S-R x2 Weight : 5.7kg</p> 

*Production by order

Fiber-Optic Systems

Connectors

Cables

Panels & Patchbays

Multichannel Systems

Cable Assemblies

Cable Reels

Plain reels for winding cable

Model	Weight (kg)	Description	Stackability
R460-S	9.9	Reel unit for cable winding / With caster.	×
R380-S	8.3	Reel unit for cable winding / With caster.	×
R300-S	4.3	Reel unit for cable winding.	○
R300	4.3	Front panel can be refurbished to create connector mounting holes.	○
R300-L	4.3	Both front panel and drum can be refurbished to create connector mounting holes.	○
R300-CN	4.3	Both panel and drum have 2 XLR connectors (one male, one female) installed.	○
R300-BN	4.3	Both panel and drum have BNC receptacles (one each).	○

- 3-position brake force adjustment. (Lock/Soft/Free)
- Non-lubricated bearings.
- Rugged E frame design.

<Wiring>

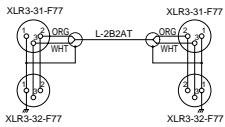

R300-CN

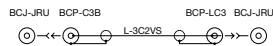

R300-BN

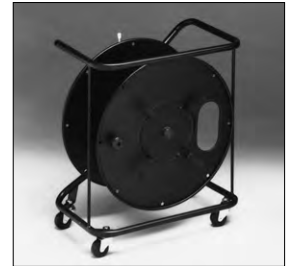

R460-S



3-position brake



R300-S

Reel with Cable Assembly

Cable detachable type.

Model	Cable reel	Description			Weight (kg)
		Set at inner end	Cable	Set at outer end	
CR100-CN	R300-CN	XLR3-12C	L-4E6S (100m)	XLR3-11C	9.6
CR100-S	R300-S	XLR3-12C	L-4E6S (100m)	XLR3-11C	9.6
CR90-BN	R300-BN	BCP-H5B	L-5C2VS (90m)	BCP-H5B	10.5



Equipped with brake

CR100-CN (with 100m cable)
L-4E6S (EC100) bundled with R300-CN.
(Set with XLR3-11C at the cable outer end when sold.)

Dimensions

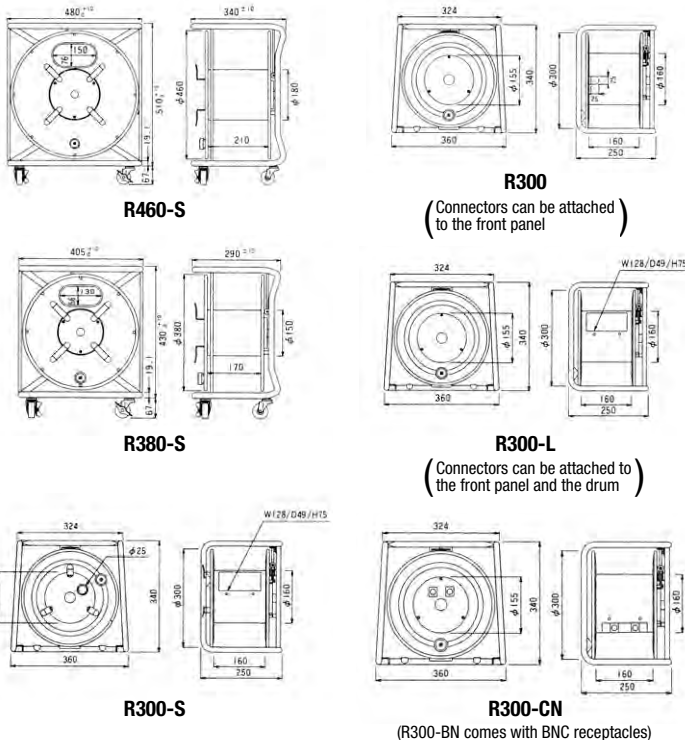

Cable winding length reference chart

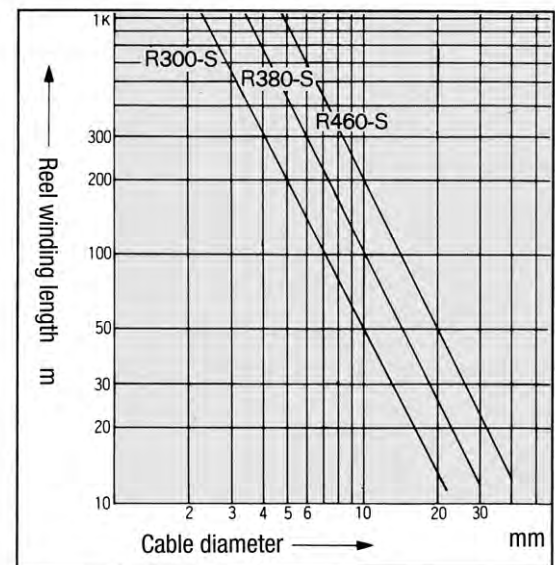

<Wind length conversion formula>

$$R300-S \quad L = \frac{8448}{D^2} \times 0.6 \text{ (m)} \quad R460-S \quad L = \frac{33852}{D^2} \times 0.6 \text{ (m)}$$

$$R380-S \quad L = \frac{18207}{D^2} \times 0.6 \text{ (m)} \quad D: \text{Cable outer diameter (mm)} \\ L: \text{wind length}$$