

Connectors

75Ω BNC Connectors

75Ω BNC Crimp Plugs

Website



Canare added the new BCP-D series for 12G-SDI. SMPTE ST 2082-1 fully compliant connector makes UHD solutions as simple as existing SDI systems. The world's highest quality BNC includes BCP-B for 3G-SDI, BCP-A/C for up to HD.

■ BCP-D Series **12G-SDI**

Return Loss: 20 dB @ 6 GHz, 15 dB @ 12 GHz

Model	Suitable Cable		Center Pin	Sleeve	Boot	Die Set
	Canare	Others				
BCP-D33UHD	L-3.3CUHD	—	BN1181	BN7003A	CB03	TCD-35CA
BCP-D33UHW	L-3.3CUHWS	—	BN1181	BN7015A	CB04	TCD-451CA
BCP-D55UHD	L-5.5CUHD	—	BN1175	B75004A	—	TCD-55UHD
BCP-D55UHW	L-5.5CUHWS	—	BN1192	BN7014	CB055W	TCD-57C
BCP-D57	—	4794R	BN1192	BN7002	—	TCD-57C
BCP-D8UHD	L-8CUHD, L-8CHD	—	BN1174	BN7147	—	TCD-8HD*

* Standard package (20pcs/100pcs)

* Crimp tool for TCD-8HD is TC-2



BCP-D55UHD

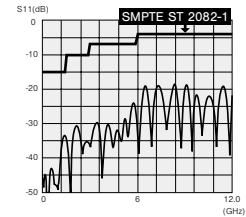

Return loss for BCP-D55UHD

■ BCP-B Series

Return Loss: 26.4 dB @ 3 GHz

Model	Suitable Cable		Center Pin	Sleeve	Boot	Die Set
	Canare	Others				
BCP-B25HD	L-2.5CHD, L-2.5CHLT	VDM230	B11015E	BN7129	CB02	TCD-35CA
BCP-B25HW	L-2.5CHWS, V4-2.5CHW	—	B11015E	BN7143	CB02	TCD-35CA
BCP-B26	—	1855A, 1855P	B11014E	BN7029C	CB02	TCD-35CA
BCP-B28	—	1855ENH, HD PRO 0.6/2.8 AF	B11015E	BN7052A	CB02	TCD-35CA
BCP-B3F	L-3CFB, V*-3CFB	—	B11015E	BN7003A	CB03	TCD-35CA
BCP-B31F	L-3CFW, V*-3CFW	—	B11015E	BN7015A	CB04	TCD-4CA TCD-451CA
BCP-B4F	L-4CHD, L-4CFB, V*-4CFB	1505A, 1505ANH, VPM2000, HD PRO 0.8/3.7 AF	B11016E	BN7015A	CB04	TCD-4CA TCD-451CA
BCP-B45HW	L-4.5CHWS	1694F	B11020D	BN7016	CB05A	TCD-35CA
BCP-B53	L-4.5CHD	1694A	B11020D	BN7046	CB05A	TCD-35CA
BCP-B56	—	HD PRO 1.0/4.8 AF	B11020D	BN7046	CB05A	TCD-35CA
BCP-B5F	L-5CFB, V*-5CFB	—	B11020D	B75004A	CB05A	TCD-5CF TCD-55FA
BCP-B51F	L-5CFW, V*-5CFW	—	B11020D	B75004A	CB05A	TCD-5CF TCD-55FA

* Standard package (20pcs/100pcs)



BCP-B53

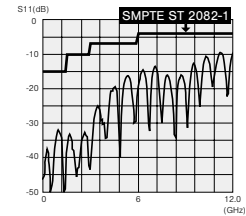

Return loss for BCP-B53

■ BCP-A Series

Return Loss: 26.4 dB @ 2 GHz, 20.8 dB @ 3 GHz (*1)

Model	Suitable Cable		Center Pin	Sleeve	Boot	Die Set
	Canare	Others				
BCP-A25	L-2.5C2V	—	BN1018A	BN7029C	CB02	TCD-35CA
BCP-A25F	L-2.5CFB	1855A, 8218, 1417B, 1418B	B11014E	BN7029C	CB02	TCD-35CA
BCP-A3	L-3C2VS, L-3C2V, V*-3C	—	B11014E	BN7003A	CB03	TCD-35CA
BCP-A31	L-3C2W	—	B11014E	BN7011	CB04	TCD-31C
BCP-A3AHD	L-3C-AHD	—	B11016E	BN7003A	CB03	TCD-35CA
BCP-A3F	L-3CFB, V*-3CFB	—	B11015E	BN7003A	CB03	TCD-35CA
BCP-A4	LV-61S	8241, 8279, RG-59B/U	B11015E	BN7015A	CB04	TCD-4CA TCD-451CA
BCP-A42	—	1505F	B11016E	BN7011	CB04	TCD-31C
BCP-A4F	L-4CHD, L-4CFB, V*-4CFB	1505A, 1505ANH, 8212, 8241F, 9167, 9259, 9659, VPM2000, HD PRO 0.8/3.7 AF	B11016E	BN7015A	CB04	TCD-4CA TCD-451CA
BCP-A5	L-5C2VS, L-5C2V, V*-5C	—	B11016E	BN7016	CB05A	TCD-35CA
BCP-A52	L-5C2W	—	B11016E	BN7014	—	TCD-451CA
BCP-A55	—	1695A, VSD2001TS	B11020D	BN7045A	CB04	TCD-35CA
BCP-A5F	L-5CFB, V*-5CFB	—	B11020D	B75004A	CB05A	TCD-35CA
BCP-A77	LV-77S	8281F	B11016E	B75004A	CB05A	TCD-5CF TCD-55FA
BCP-VA3	V*-3C	—	B11014E	BN7052A	CB03	TCD-35CA
BCP-VA5	V*-5C	—	B11016E	BN7045A	CB05A	TCD-35CA

* Standard package (20pcs/100pcs).

*1 Excluding BCP-A25, BCP-A25F and BCP-A4

Note: Suitable die set for BCP-A5F is TCD-35CA; do not use TCD-5CF/TCD-55FA for BCP-A5F.

- Canare crimp design ensures quick and reliable installation.
- Gold plated "snap locks" center pin and beryllium copper outer contact.
- Elongated body design for stable finger grip.
- Position mark on the body makes it easier to check if the connector is locked.

Be sure to use Canare Crimp Tool



BCP-A3

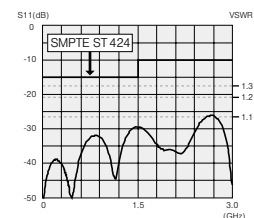

Return loss for BCP-A3

■ BCP - C Series

Return Loss : 26.4 dB @ 2 GHz (*2)

Model	Suitable Cable		Center Pin	Sleeve	Boot	Die Set
	Canare	Others				
BCP - C1	L-1.5C2VS, V*-1.5C	83264, 83267	Solder	BN7022	CB01	TCD-1DB
BCP - C5HD	L-5CHD	—	BN1139	B75004A	CB05A	TCD-5HD
BCP - C6HD	L-6CHD	—	BN1083A	BN7074A	—	TCD-67HD
BCP - C71A	—	7731A, 9064, 9292, 1617A, 9011	BN1043A	BN7021A	—	TCD-7CA
BCP - C7FA	L-7CFB	—	BN1012B	BN7021A	—	TCD-7CA
BCP - C7HD	L-7CHD	—	BN1082A	BN7021A	—	TCD-67HD

* Standard package (20pcs/100pcs).

*2: Excluding BCP-C1



BCP - C6HD



BCP - LC3



BCP - LD25HD

■ BCP-LD Series (Right Angle) **12G-SDI**

Return Loss : 20 dB @ 6 GHz / 15 dB @ 12 GHz

Model	Suitable Cable		Center Pin	Sleeve	Boot	Die Set
	Canare	Others				
BCP-LD25HD	L-2.5CHD	1855A	BN1223	BN7129	—	TCD-35CA
BCP-LD25HW	L-2.5CHWS	—	BN1223	BN7143	—	TCD-35CA
BCP-LD33UHD	L-3.3CUHD	—	BN1225	BN7003A	—	TCD-35CA
BCP-LD53	L-4.5CHD	1694A	BN1226	BN7046	—	TCD-35CA

* Standard package (20pcs/100pcs)

■ BCP-LC Series (Right Angle)

Return Loss : 26.4 dB @ 2 GHz

Model	Suitable Cable		Center Pin	Sleeve	Boot	Die Set
	Canare	Others				
BCP-LC3	L-3C2VS, L-3C2V, V*-3C	—	B11014E	BN7003A	—	TCD-35CA
BCP-LC3F	L-3CFB, V*-3CFB	—	B11015E	BN7003A	—	TCD-35CA
BCP-LC5	L-5C2VS, L-5C2V, V*-5C	—	B11016E	BN7016	—	TCD-35CA
BCP-LC5F	L-5CFB, V*-5CFB	—	B11020D	B75004A	—	TCD-5CF TCD-55FA

* Standard package (20pcs/100pcs).

- Canare crimp design ensures quick and reliable installation.
- Gold plated "snap locks" center pin and beryllium copper outer contact.

Be sure to use Canare Crimp Tool

Website



75Ω Slim BNC Crimp Plugs

■ MBCP - C Series

Return Loss : 26.4 dB @ 1.5 GHz (*3)

Model	Suitable Cable		Center Pin	Sleeve	Boot	Die Set
	Canare	Others				
MBCP - C25F	L-2.5CFB	1855A, 8218, 1417B, 1418B	B11014E	BN7029C	—	TCD-35CA
MBCP - C3F	L-3CFB, V*-3CFB	—	B11015E	BN7003A	CB24	TCD-35CA
MBCP - C4	LV-61S	8241, 8279, RG-59B/U	B11015E	BN7015A	CB25	TCD-4CA TCD-451CA
MBCP - C4F	L-4CFB, V*-4CFB	1505A, 1505ANH, 8212, 8241F, 9167, 9259	B11016E	BN7015A	CB25	TCD-4CA TCD-451CA
MBCP - C53	L-4.5CHD	1694A, 9066, 9116, 9118, 9248	B11020D	BN7046	CB26	TCD-35CA
MBCP - C5F	L-5CFB, V*-5CFB	—	B11020D	B75004A	CB26	TCD-5CF TCD-55FA

* Standard package (20pcs)

*3: Excluding MBCP-C25F

- Slim design : O.D. 12 mm
- Compatible with 75Ω BNC receptacles.
- Canare crimp design ensures quick and reliable installation.
- Gold plated "snap locks" center pin and beryllium copper outer contact.

Be sure to use Canare Crimp Tool

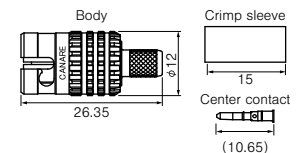

MBCP - C3F

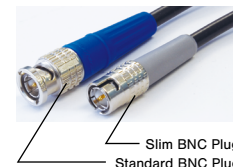

Technical Note

Voltage Standing-wave Ratio (VSWR) and Return Loss

Terminating the receiving end of a limited length coaxial cable using a resistance value not equal to its characteristic impedance creates a reflected wave that returns back down the cable to the sending end. The result is interference developing between the travelling wave and the return wave which results in a standing wave that causes voltage levels to fluctuate. The degree to which terminating resistance matches the characteristic impedance is indicated using the VSWR or voltage standing-wave ratio standard shown in Fig. 1. Going hand in hand with the VSWR ratio is the return loss factor which measures the size of the reflected wave current in relation to the travelling wave current. (See Fig. 2)

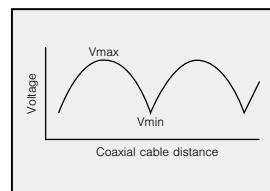

Fig. 1 Voltage Distribution Over Coaxial Cable

VSWR	Return Loss (dB)
2	9.54
1.5	13.98
1.2	20.83
1.1	26.44
1.05	32.26
1.02	40.09
1.01	46.06

Fig. 2 VSWR to Return Loss Conversion Table

Connectors

75Ω BNC Connectors

75Ω BNC Solder Plugs

■ BCP-H Series

Return Loss : 26.4 dB @ 1 GHz

Model	Suitable Cable	
	Canare	Others
BCP-H3B	L-3C2VS, L-3C2V, L-3CFB	—
BCP-H31F	L-3CFW	—
BCP-H45HW	L-4.5CHWS	1694F
BCP-H5B	L-5C2VS, L-5C2V, L-5CFB	—
BCP-H51F	L-5CFW, L-5CFB	—
BCP-H5/1	L-3C2VS, L-3C2V, L-3CFB L-5C2VS, L-5C2V, L-5CFB	—

• Standard package (20pcs)

- The tubular (ferrule) section is silver plated to make soldering easier.
- Cable stripper TS100E can be used. (Excluding BCP-H31F, BCP-H51F)



BCP-H3B

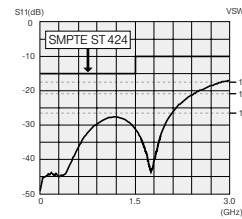

Return loss for BCP-H3B



75Ω BNC Jack Plug

Model	Suitable Cable	Center Pin	Sleeve	Boot	Die Set
BCJ-C4	RG-59 B/U, LV-61S, Belden 8241, 8279, 88241	Solder	V75001	CB25	TCD-4CA TCD-451CA
BCJ-D25HD	L-2.5CHD	BN1204	BN7159	—	TCD-D253F
BCJ-D25HW	L-2.5CHWS	BN1204	BN7158	—	TCD-D253F
BCJ-D33UHD	L-3.3CUHD	BN1205	BN7003A	—	TCD-D253F

• Standard package (20pcs)

- Return loss for BCJ-C: 26.4 dB @ 1.5 GHz, 20.8 dB @ 2.4 GHz
- Return loss for BCJ-D: 20 dB @ 3 GHz, 15 dB @ 6 GHz, 10 dB @ 12 GHz

Be sure to use Canare Crimp Tool

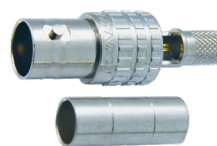

BCJ-C4

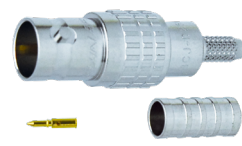

BCJ-D25HW

12G-SDI



75Ω BNC Extension Adapter

Model	Description
BCJ-JK	Jack to Jack, for 12G-SDI

• Standard package (20pcs/100pcs)

- Return loss for BCJ-JK: 15 dB @ 12 GHz



BCJ-JK

12G-SDI

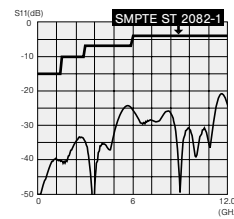

Return loss for BCJ-JK

75Ω BNC Termination Plugs

Model	Description
BCP-TK	True 75Ω Termination, for 12G-SDI
BCP-TK-CH	BCP-TK with String

• Standard package (20pcs/100pcs)

- Includes 1/4 watt resistance.
- Return loss for BCP-TK: 26.4 dB @ 3 GHz, 15 dB @ 12 GHz



BCP-TK

12G-SDI

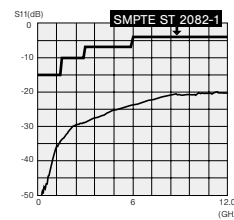

Return loss for BCP-TK

Connector Boots

■ CB0* Series

Our best selling connector boots for Canare BNC, TNC crimp plugs.

Model	Colors Available	BCP-**	BP-**	TNP-**
CB01	BLK BLU GRN RED YEL WHT	C1		
CB02		B25HD, B25HW, B26, B28, A25, A25F		
CB03	BLK BLU BRN GRN GRY	D33UHD, B3F, A3, A32, A3AHD, A3F, VA3	C3, C4	C3, C4
CB04	ORN PPL RED YEL WHT	D33UHW, B31F, B4F, A31, A4, A42, A4F, A55	C31	C31
CB05A		B53, B56, B5F, B51F, A5, A5F, A77, VA5, C5HD	C5, C5FA	C5
CB055W	BLK	D55UHW		

■ CB2* Series

Thinner type of CB0* series. Best fit for Canare Slim BNC, RCA, and F crimp plugs.

Model	Colors Available	Typical Connectors		
		MBCP-**	RCAP-**	FP-**
CB24		C3F	C3A, C3F	C3, C3F
CB25	BLK BLU GRN RED YEL WHT	C4, C4F	C3GS, C4A, C4F	C31, C4, C4F
CB26		C5F	C53, C5A, C5F	C5, C53A, C5F

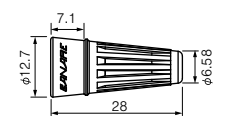

CB01, CB02

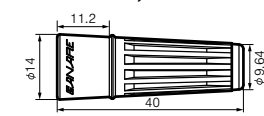

CB03, CB04, CB05A

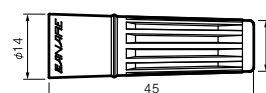

CB055W



CB24, CB25, CB26

75Ω BNC Receptacles

■ **Jack to Jack** **12G-SDI** Return Loss: 15 dB @ 12 GHz

Model	Description	Flange
BCJ-JRK	Standoff	—
BCJ-JRUK	Flush-mount	ITT XLR-F77
BCJ-JRUDK		Neutrik D
BCJ-JRUDBK		Neutrik D (Black)

- Standard package (20 pcs)
- Redesigned for 12G-SDI to minimize return loss.

■ **Jack to Solder** Return Loss: 26.4 dB @ 2 GHz

Model	Description	Flange
BCJ-R	Rear-mount	—
BCJ-R/1	Rear-mount, w/Ground Lug	—
BCJ-RU	Flush-mount	ITT XLR-F77
BCJ-RUD		Neutrik D
BCJ-RUDB		Neutrik D (Black)

- Standard package (20 pcs)

■ **Panel Jack (Jack to Solder and Crimp)** Return Loss: 26.4 dB @ 1 GHz

Model	Description	Flange	Suitable Cable	Die Set
BCJ-FC1	Front-mount, 1/2"	—	1.5C-2V	TCD-1DB
BCJ-FC1-7/16	Front-mount, 7/16"	—		
BCJ-RUC1	Flush-mount	ITT XLR-F77		

- Standard package (20 pcs)
- Panel Jack covers the rear wiring part with metal crimp sleeve.
- Flush-mount receptacle prevents damage on the jack.

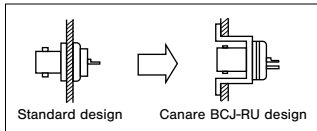

■ **Panel Hole Dimensions**

BCJ-R	★BCJ-R/1 ★BCJ-JRK	BCJ-FC1	★BCJ-FC1-7/16	BCJ-RUC1 BCJ-RU BCJ-JRUK	BCJ-RUD BCJ-RUDB BCJ-JRUDK BCJ-JRUDBK

★ marked models accept insulation bushing IU-7/16, and the panel hole for IU-7/16 should be adopted in this case. (see below)

Insulation Bushing

Model	Description
IU-7/16	ABS plastic

- Standard package (20 pcs)
 - Insulate a connector from a panel.
 - 6 colors available (white, black, blue, green, red, or yellow)
- Note:** Please remove washers from a connector before using IU-7/16.

Panel Thickness:

- 1.2 to 1.5 mm: BCJ-DCJ, BCJ-FPLHA, BCJ-FPLV-12G, BCJ-FPLV-L, BCJ-FPLVA, BCJ-HBCJK, BCJ-R/1
- 1.2 to 3.0 mm: BCJ-FC1-7/16, BCJ-FPC, BCJ-FPC02, BCJ-FPLV01, BCJ-JRK, BCJ-JR, FJ-JR, FJ-FPC, NCJ-BCJR, RJ-JR

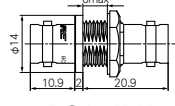
Website



BCJ-JRK

BCJ-JRUK

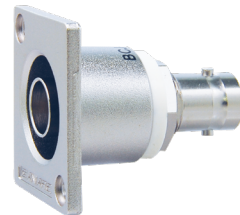
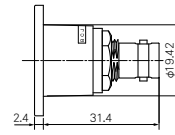
BCJ-R/1

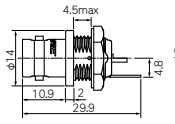
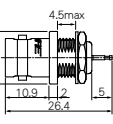
BCJ-R/1

BCJ-R

BCJ-RU

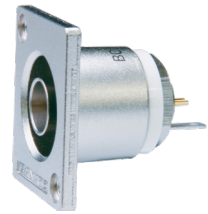
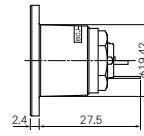
BCJ-RUD

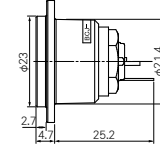
BCJ-FC1-7/16

BCJ-FC1-7/16

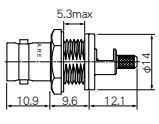
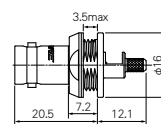
BCJ-FC1



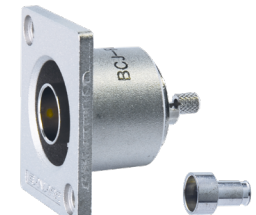
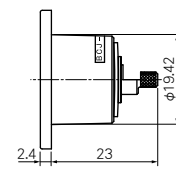

BCJ-RUC1

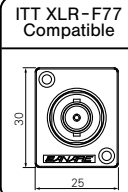
ITT XLR-F77
Compatible

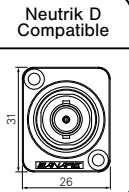

Neutrik D
Compatible





Website

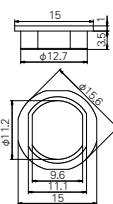
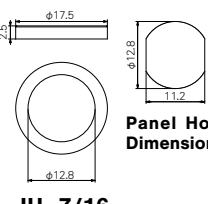

IU-7/16

Connectors

75Ω BNC Connectors

75Ω BNC PCB Mount Receptacles (Screw Type)

■ Front Mount

Model	Description	Stud Position	Panel Mount	Standard Package
BCJ-BPLHK	Right Angle, for 12G-SDI	Horizontal	Front : M2.6 screw	20 pcs/100 pcs
BCJ-BPLHA	Right Angle			20 pcs/100 pcs
BCJ-BPLHK2P	Right Angle, Dual Jack, for 12G-SDI			10 pcs
BCJ-BPLH2PA	Right Angle, Dual Jack			10 pcs
BCJ-BPLH3PA	Right Angle, Triple Jack			10 pcs
BCJ-BPCK	Straight, for 12G-SDI			20 pcs
BCJ-BPC2P	Straight, Dual Jack	—	10 pcs/100 pcs	

Screws not included

Key Features and Benefits

- True 75Ω PC board mount receptacle.
- Gold plated beryllium copper center contact.
- Right Angle types can be fixed on PC board with M2.6 screw.
- Space-saving design
- Eliminates wiring material and cost.

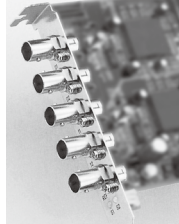

Note : Any cleaning solvents cannot be used. This leads to insulation problems.
Insulation material : m-PPO (m-PPE)

< Return loss >

BCJ-BPLHK : 26 dB @ 1.5 GHz, 20 dB @ 3 GHz, 15 dB @ 6 GHz, 10 dB @ 12 GHz

BCJ-BPLHA : 26 dB @ 1.5 GHz, 20 dB @ 3 GHz

BCJ-BPCK : 26 dB @ 1.5 GHz, 20 dB @ 3 GHz, 15 dB @ 6 GHz, 10 dB @ 12 GHz

BCJ-BPC2P : 26 dB @ 1 GHz, 20 dB @ 2.5 GHz

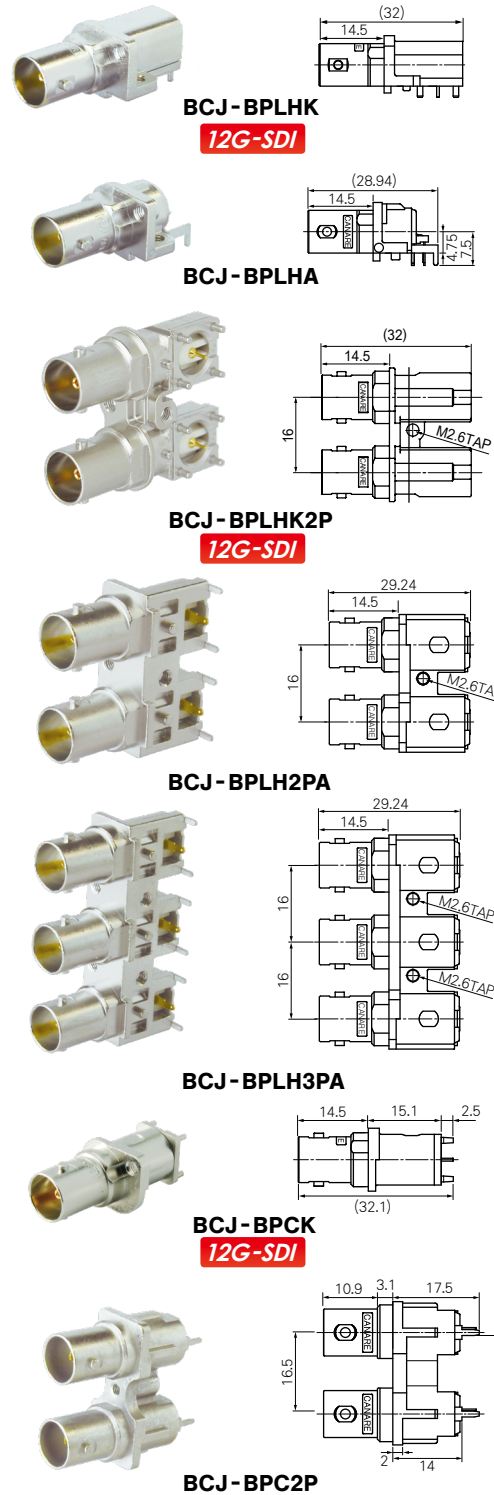
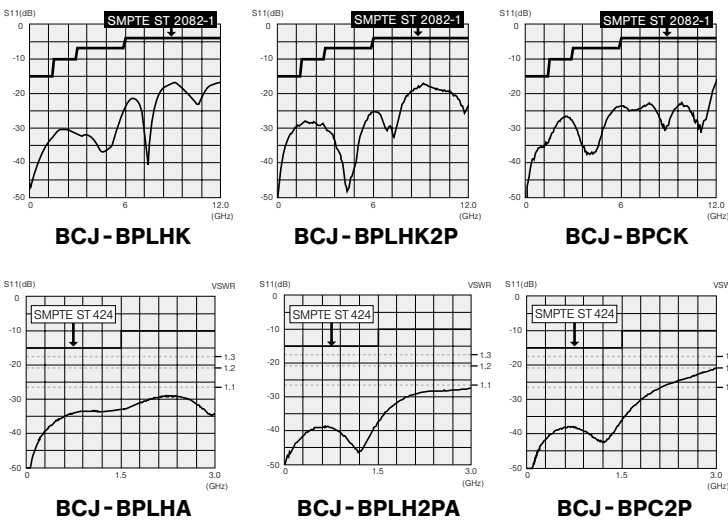

Website

	BCJ-BPLHK	BCJ-BPLHA	BCJ-BPLHK2P BCJ-BPLH2PA	BCJ-BPLH3PA	BCJ-BPCK	BCJ-BPC2P
Panel Hole Dim.	 Screw : M2.6 t1.6	 Screw : M2.6 t1.6	 Screw : M2.6 t1.6	 Screw : M2.6 t1.6	 Screw : M2.6 t1.6	 Screw : M2.6 t1.2
PCB Hole Dim.	 t2.0 (BOTTOM VIEW)	 t2.0 (BOTTOM VIEW)	 t2.0 (BOTTOM VIEW)	 t1.6 (BOTTOM VIEW)	 t2.0 (BOTTOM VIEW)	 t1.6 (BOTTOM VIEW)

75Ω BNC PCB Mount Receptacles (Hex Nut Type)

Front Mount

Model	Description	Stud Position	Panel Mount
BCJ-FPLV-12G	Right Angle, for 12G-SDI	Vertical	Front: Hex nut and lock washer
BCJ-FPLVA	Right Angle		
BCJ-FPLV01	Right Angle, Low Cost		
BCJ-FPLV-L	Right Angle, Long Neck		
BCJ-FPLHA	Right Angle	Horizontal	
BCJ-FPC	Straight	—	
BCJ-FPC02	Straight, Low Cost	—	

• Standard package: 20pcs/100pcs, except for BCJ-FPLV-L (10pcs).

Rear Mount

Model	Description	Stud Position	Panel Mount
BCJ-RPC	Straight, Through Hole Mount	—	Rear: Hex nut and lock washer
BCJ-RPC/1	Straight, Surface Mount		

• Standard package: 20pcs/100pcs.

- BCJ-FPLV-12G is specially designed to minimize the return loss for 12G-SDI.
- Return loss: BCJ-FPLV-12G: 15 dB @ 6 GHz, 10 dB @ 12 GHz, BCJ-FPLV-L: 26.4 dB @ 3 GHz, Others: 26.4 dB @ 1 GHz.

Note: Any cleaning solvents cannot be used. This leads to insulation problems.
Insulation material: m-PPO (m-PPE)

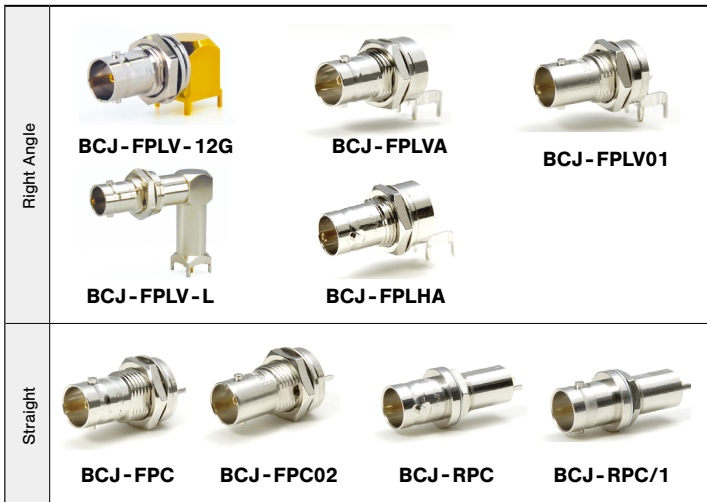

<Panel Hole Dimensions>

BCJ-FPLV-12G* BCJ-FPLVA* BCJ-FPLV01* BCJ-FPLV-L*	BCJ-FPLHA*	BCJ-FPC* BCJ-FPC02*	BCJ-RPC/1 BCJ-RPC

* BCP-FP series accept insulation bushing IU-7/16, and the panel hole for IU-7/16 should be adopted in this case. (see page 24)

<PC Board Hole Dimensions>

BCJ-FPLV-12G	BCJ-FPLVA BCJ-FPLV01 BCJ-FPLHA	BCJ-FPLV-L	BCJ-FPC BCJ-FPC02	BCJ-RPC



BCJ-FPLV-12G
12G-SDI

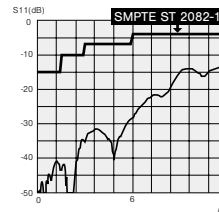

Return loss for BCJ-FPLV-12G

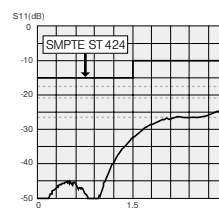

Return loss for BCJ-FPLV01

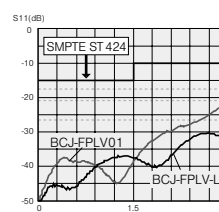

Return loss for BCJ-FPLV01, BCJ-FPLV-L

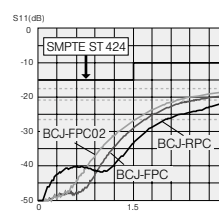

Return loss for BCJ-FPC, BCJ-FPC02, BCJ-RPC

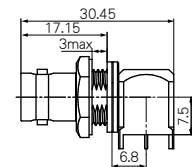

BCJ-FPLV-12G

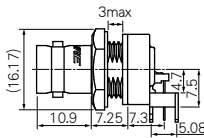

BCJ-FPLVA

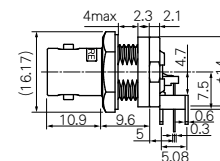

BCJ-FPLV01

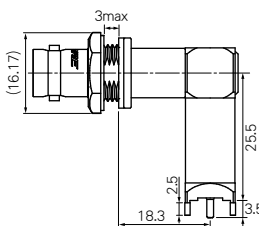

BCJ-FPLV-L

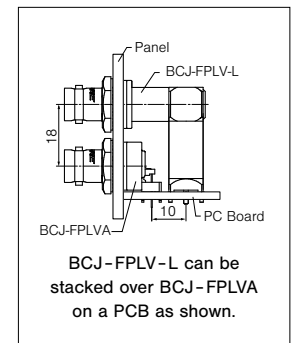

BCJ-FPLV-L can be stacked over BCJ-FPLVA on a PCB as shown.

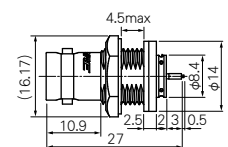

BCJ-FPC

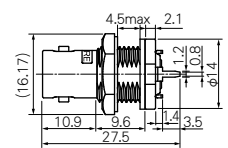

BCJ-FPC02

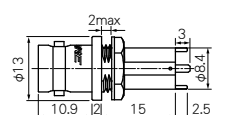

BCJ-RPC



Website

Technical Trend

IP Connectivity Products

Fiber-Optic Systems

Connectors

Cables

Panels & Patchbays

Multichannel Systems

Cable Assemblies

Connectors

Active BNC

12G-SDI Active BNC

12G-SDI Active BNC integrating I/O interface device inside. It frees you from struggling with PCB design coping with return loss and board space.

BCAK 12G-SDI

*Card Edge Connector NOT included

Model	Form	Type	Built-in IC
BCAK-TL	Right Angle	TX	Cable Driver
BCAK-RL		RX	Cable Equalizer
BCAK-BL		BiDi	Cable Driver & Equalizer
BCAK-TS	Straight	TX	Cable Driver
BCAK-RS		RX	Cable Equalizer
BCAK-BS		BiDi	Cable Driver & Equalizer

Sales unit : 5 pcs

- Assembled on a PC board with SMT Card Edge Connector. The pluggable 2-piece structure improves productivity and replaceability.

*Card Edge Connector sold separately

- Supports 12G/6G/3G/HD/SD-SDI
- Reduce entire development cost as well as development period.
- 16 mm : Minimum pitch between adjacent connectors
- Straight models can be mounted on the same board at the same height as 3G-SDI Active BNC.
- PIN control : status monitoring and mode change
- Command control for optimization and characterization
- Cable driver and equalizer with reclocker
- TX/RX/BiDi identification by insulation color

SMT Card Edge Connectors 12G-SDI

Model	Form	Suit for
AKU-20LFYG	Right Angle	BCAK-TL/RL/BL
AKU-20SFYG	Straight	BCAK-TS/RS/BS

Sales unit : 5pcs

- Card Edge Connector for BCAK.
- Same footprint for TX, RX and BiDi.
- Applicable for reflow soldering.

Specifications

Type	TX	RX	BiDi TX mode	BiDi RX mode
Supply Voltage	DC 2.5 V			
Current Consumption	195 mA	120 mA	128 mA	115 mA
Operating Temperature	-40 deg C to +85 deg C			
Output Amplitude	800 mV	N/A	800 mV	N/A
Equalization	N/A	12G-SDI 100m over L-5.5CUHD	N/A	12G-SDI 100m over L-5.5CUHD
Standards	SMPTE ST 2082-1, 2081-1, 424, 292, 259 BTA S-004C, EN 50083-9			
Weight	Right Angle : 9 g, Straight : 10 g			

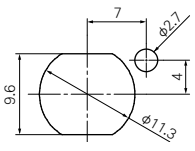
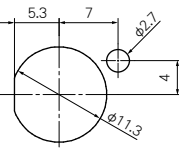
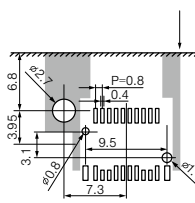
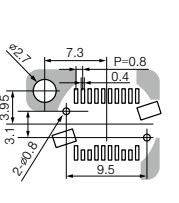
	Right Angle	Straight
Panel Hole Dim.	 1.6 Screw : M2.6	 1.6 Screw : M2.6
PCB Hole Dim.	 use a M2.6 screw to fix BCAK to PCB.	 use a M2.6 screw to fix BCAK to PCB.

The dark shaded areas come into contact with the connector body.

Website

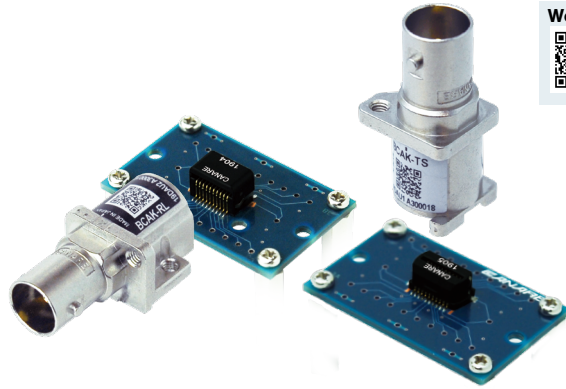

BCAK-TL



BCAK-TS



BCAK-RL



BCAK-RS



BCAK-BL



BCAK-BS

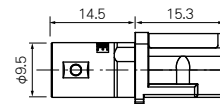

(Right Angle)

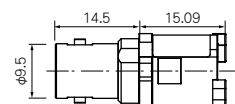

(Straight)

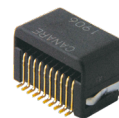

AKU-20LFYG



AKU-20SFYG

<Color Identifications>

Example) front view of Right Angle



TX
Insulation color
white



RX
Insulation color
black



BiDi
Insulation color
light gray

3G-SDI Active BNC

Small BNC connector incorporates either a cable equalizer or a cable driver. Active BNC makes innovation in your 3G-SDI PC board layout.



Model	Form	Type	Built-in IC
BCA-TL	Right Angle	TX	Cable Driver
BCA-RL		RX	Cable Equalizer
BCA-TS	Straight	TX	Cable Driver
BCA-RS		RX	Cable Equalizer

Sales unit: 5 pcs

- BNC connector integrated with a cable equalizer or a cable driver, and yet keep the connector size to a minimum.
- Support 3G/HD/SD-SDI
- Offers an excellent return loss performance without designing 75Ω I/O Circuit
- Simplifies PCB design process dramatically and will reduce entire development cost
- PCB space saving and help to downsize devices
- TX/RX identification by insulation color

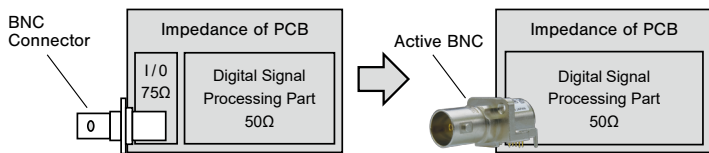

Simplify Your Circuit Design

<Color Identifications>

Example) front view of Right Angle

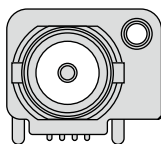

TX
Insulation color white

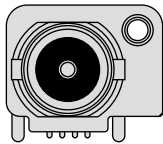

RX
Insulation color black

Specifications

Model	TX BCA-TL, BCA-TS	RX BCA-RL, BCA-RS
Supply Voltage	DC 3.3V	
Current Consumption	50 mA	70 mA
Operating Temperature	-25 deg C to +85 deg C	
Output Amplitude	800 mVpp	N/A
Equalization	N/A	3G-SDI 120m over L-5CFB
Standards	SMPTE ST 424, 292, 259, BTA S-004C, EN 50083-9	
Weight	9 g	



BCA-TL

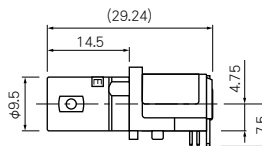

(Right Angle)



BCA-RS

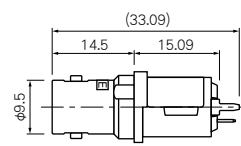

(Straight)

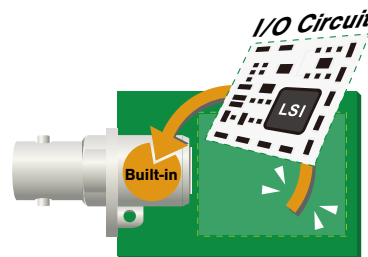

Space-saving

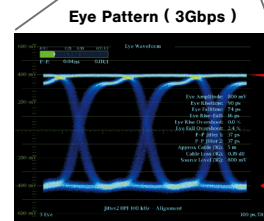
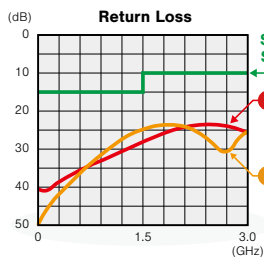
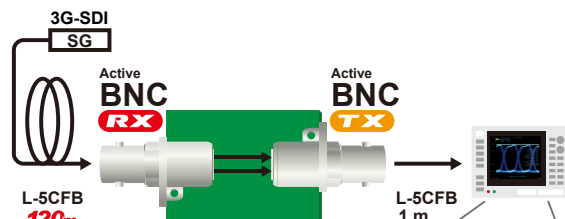

	BCA-TL	BCA-RL	BCA-TS	BCA-RS
Panel Hole Dim.	<p>t1.6 Screw: M2.6</p>		<p>t1.6 Screw: M2.6</p>	
PCB Hole Dim.	<p>Pin 8 5 1234 1: GND 2: SDI+ 3: SDI- 4: Vcc 5: SD/HD 6: - 7: - 8: ENABLE</p> <p>t2.0 (TOP VIEW)</p>	<p>Pin 1234 1: GND 2: SDO- 3: SDO+ 4: Vcc</p> <p>t2.0 (TOP VIEW)</p>	<p>Pin 4321 5 8 1: GND 2: SDI+ 3: SDI- 4: Vcc 5: SD/HD 6: - 7: - 8: ENABLE</p> <p>t2.0 (TOP VIEW)</p>	<p>Pin 4321 1: GND 2: SDO- 3: SDO+ 4: Vcc</p> <p>t2.0 (TOP VIEW)</p>

The dark shaded areas come into contact with the connector body.

Connectors

75Ω Micro BNC Connectors

75Ω Micro BNC Connectors

Website



All Canare micro BNC connectors are designed for SMPTE ST 2082-1 spec. Ideal for cabling 12G-SDI routers, switchers, and SFP modules. PCB connectors will allow greater flexibilities of the number of video interface.

■ Crimp Plugs **12G-SDI** Return loss : 26dB @ 3GHz, 20dB @ 6GHz, 15dB @ 12GHz

Model	Suitable Cable		Center Pin	Sleeve	Die Set	Extraction Tools
	Canare	Others				
HBCP-D25HDA	L-2.5CHD, L-2.5CHLT	1855A	BN1214	BN7136	TCD-D253F	BET-D/H, BET-HBNC, Common Tool
HBCP-D25HWA	L-2.5CHWS, V4-2.5CHW	—	BN1214	BN7141		
HBCP-D33UHDA	L-3.3CUHD	—	BN1215	BN7003A		
HBCP-D53A	L-4.5CHD	1694A	BN1218	BN7016	TCD-D534F	BET-D/H Common Tool
HBCP-D55UHD	L-5.5CUHD	—	BN1219	B75004A	TCD-55UHD	

• Standard package (20 pcs)

- SMPTE ST 2082-1 compliant.
- Canare crimp design ensures quick and reliable installation.
- Gold plated "snap locks" center pin.
- Beryllium copper outer contact.
- Come with a position mark on the body for better visibility mating.

Be sure to use Canare Crimp Tool



HBCP-D25HDA

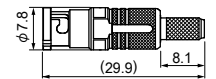

HBCP-D25HDA

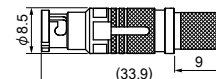

HBCP-D53A

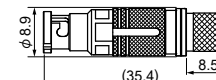

HBCP-D55UHD

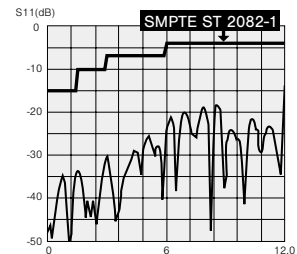

Return loss for HBCP-D25HDA

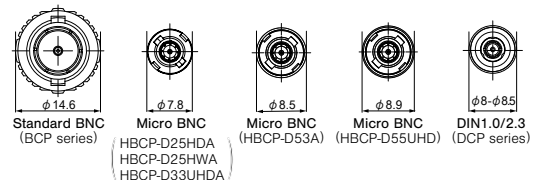

Comparison of connector body diameter
* for reference only

The New Canare HBCP Series

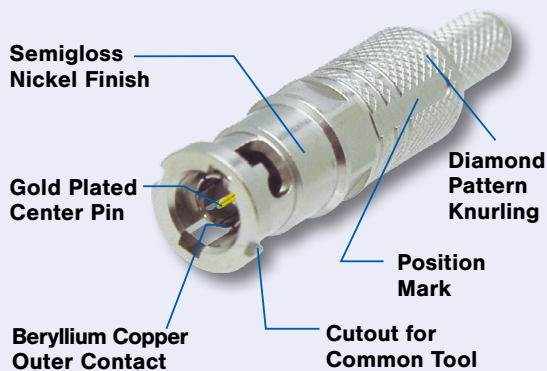

Model	HBCP-D25HDA HBCP-D25HWA HBCP-D33UHDA	HBCP-D53A HBCP-D55UHD	Previous Models HBCP-D25HD HBCP-D25HW HBCP-D33UHD HBCP-D53
Return Loss	≥15dB@DC-12GHz	≥15dB@DC-12GHz	≥8dB@DC-12GHz
Connector OD	φ 7.8mm	φ 8.5-8.9mm	φ 7.82-8.5mm
Extraction Tools / Distance Between Center of Plugs			
BET-D/H: 12mm	Yes	Yes	Yes
BET-HBCP: 8mm	Yes	No	No
Common Tools: Min. 8mm	Yes	Yes	No
Application	Rack wiring, Extremely narrow space, Video SFP	50-100M distance range, 12G-SDI sensitive connection	Rack Wiring, Narrow space, 12G-SDI routers/ switchers

Tools

Model	Description	Suitable Connector
BET-HBNC	Extraction tool	HBCP-D25HDA, D25HWA, D33UHDA
BET-D/H	Extraction tool	DCP-C, HBCP-D series, HBCP-DA series

• Extraction tool BET-D/H is available for both Canare Micro BNC and DIN plugs.

HBCP-D25HDA with BET-HBNC



12G Router / Switcher



12G SFP Module



BET-HBNC



BET-D/H

PCB Mount Receptacles **12G-SDI**

Return Loss: 20 dB @ 3 GHz, 10 dB @ 12 GHz

Model	Description	Nut Driver Bit
HBCJ-LRK	Right Angle	NDT-HBC
HBCJ-LRK/1	Right Angle, Long type	
HBCJ-FEMK	Edge Mount	

- Standard package (20 pcs)
 - SMPTE ST 2082-1 compliant
 - Combination of HBCJ-LRK/1 and HBCJ-FEMK offers efficient PCB mount Solution.
- Note:** Nut driver bit NDT-HBC is required.

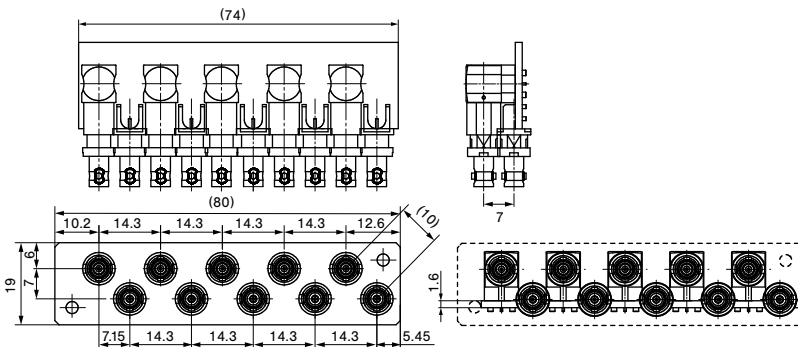

HBCJ-LRK

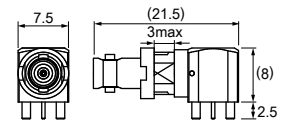

HBCJ-LRK



HBCJ-LRK/1

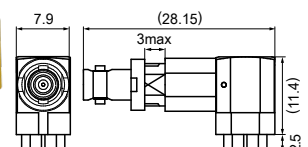

HBCJ-LRK/1



HBCJ-FEMK

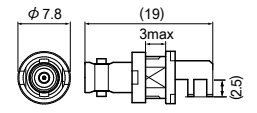

HBCJ-FEMK

Adapters **12G-SDI**

Return Loss: 20 dB @ 3 GHz, 10 dB @ 12 GHz

Model	Description	Nut Driver Bit
HBCJ-JRK	Jack to Jack	NDT-HBC (for panel mounting)
BCJ-HBCJK	BNC Jack to Micro BNC Jack	

- Standard package (20 pcs)
- SMPTE ST 2082-1 compliant
- Panel mountable

Tool

Model	Description	Suitable Connector
NDT-HBC	Nut driver bit, 6.35 mm (1/4") hex shank	HBCJ, BCJ-HBCJK



HBCJ-JRK

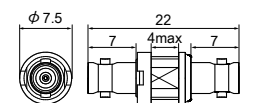

HBCJ-JRK



BCJ-HBCJK

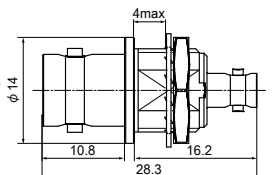

BCJ-HBCJK

<Panel Hole Dim.>

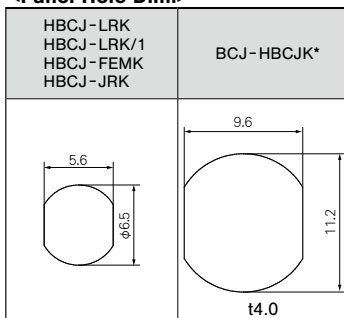

<PCB Hole Dim.>

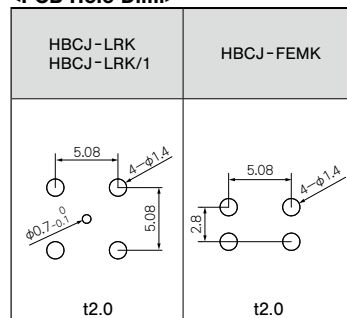

NDT-HBC*

* Torque driver not included.

* BCJ-HBCJK accept insulation bushing IU-7/16. See page 24 for the panel hole with IU-7/16.

Connectors

75Ω BNC, 75Ω N, Connectors

BNC Dust Caps

Model	Description
BCJ-DC	Polyethylene (Black)
BCJ-DC-CH	Polyethylene (Black) with string

• Standard package (20pcs/100pcs)

- Protects unused BNC receptacles from dirt and dust.

BNC - RCA Adapter

Model	Description
BCP-RCAJ	RCA Jack (F) to BNC Plug (M)
BCJ-RCAP	BNC Jack (F) to RCA Plug (M)

• Standard package (1pc)

- Gold plated center contact
- Secure finger grip and reliable mating

75Ω N Solder Plug

Return Loss : 26.4 dB @ 2 GHz

Model	Suitable Cable
NCP-H8HD	L-8CHD

• Standard package (1pc)

- Gold plating on the contact pin prevents deterioration, even after years of use.
 - Return loss : 26.4 dB @ 2 GHz
 - Solder type
- Tools required : 17 mm and 21 mm wrenches

Caution: The connecting section of the N connector uses a shape that conforms to the IEC169-16's 75Ω impedance standard. Note that the 50Ω N and other connectors that do not conform to this specification cannot be connected.

75Ω N to BNC Adapter

Return Loss : 26.4 dB @ 2 GHz

Model	Description
NCJ-BCJR	N (F) - BNC (F)

• Standard package (1pc)

- Beryllium copper (gold plated) is used on the center contact for its superior spring characteristics.
- Return loss : 26.4 dB @ 2 GHz
- Panel mountable as well. For isolation from the panel, use Canare isolation bushing IU-7/16.(see page 24)



BCJ-DC



BCP-RCAJ

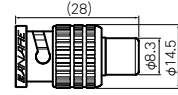

BCJ-RCAP

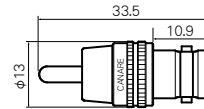

NCP-H8HD

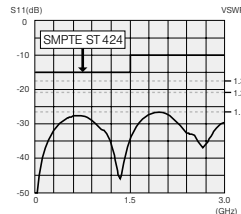
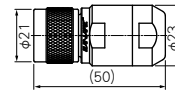

Return loss for NCP-H8HD



NCJ-BCJR

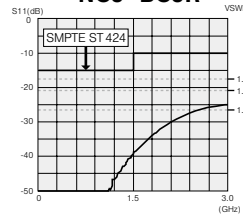

Return loss for NCJ-BCJR

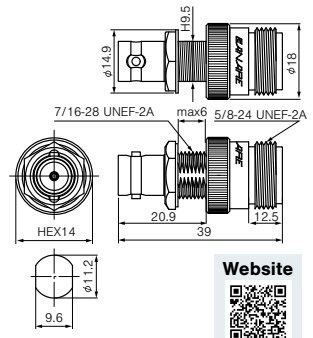

75Ω DIN 1.0/2.3 Connectors

Mini coax connectors IEC61169-29 and DIN 47 297 compatible.

■ Crimp Plugs

Return Loss: 20.8 dB @ 3 GHz

Model	Suitable Cable		Center Pin	Sleeve	Die Set
	Canare	Others			
DCP-C25HD	L-2.5CHD, L-2.5CHLT	1855A, VDM230	BN1148	BN7136	TCD-D253F
DCP-C25HW	L-2.5CHWS, V4-2.5CHW	—	BN1148	BN7141	TCD-D253F
DCP-C3F	L-3CFB	—	BN1148	BN7003A	TCD-D253F
DCP-C4F	L-4CHD, L-4CFB	1505A, VPM2000	BN1158	BN7015A	TCD-D534F
DCP-C53	L-4.5CHD	1694A, VSD2001	BN1157	BN7138	TCD-D534F

• Standard package (20pcs/100pcs)

- Our unique ball-locking mechanism offers smooth and reliable mating.
- Canare crimp design ensures quick and reliable installation.
- Elongated body design enables stable finger grip.
- Return loss: 20.8 dB or greater up to 3 GHz
- Extraction tool: BET-DIN or BET-D/H (see page 41)

US Patent No.: 8764473 B2

Be sure to use Canare Crimp Tool

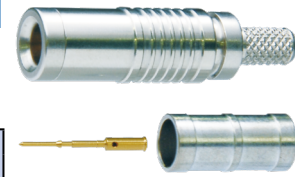

DCP-C25HD

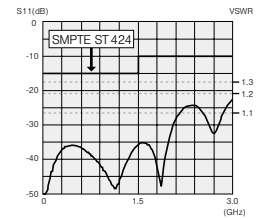

Return Loss for DCP-C25HD

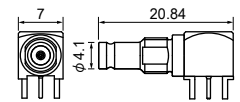

DCJ-LR

■ PCB Mount Receptacles

Return Loss: 20.8 dB @ 3 GHz

Model	Description	Nut Driver Bit
DCJ-LR	Right Angle	NDT-DIN
DCJ-LR/1	Right Angle, Long type	
DCJ-FEM	Edge Mount	

• Standard package (20 pcs)

- Compact design ideal for high density mounting and downsizing devices.
- Combination of DCJ-LR/1 and DCJ-FEM is effective for staggered arrangement.
- Return loss: 20.8 dB or greater up to 3 GHz.

Note: Nut driver bit NDT-DIN is required.

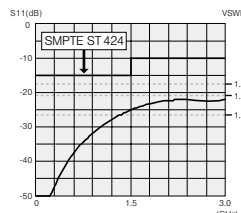

Return Loss for DCJ-LR

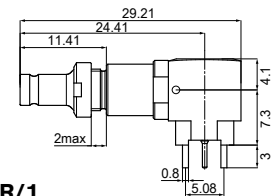

DCJ-LR/1

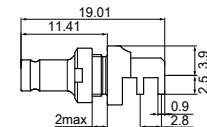

DCJ-FEM

■ Adapters

Return Loss: 26.4 dB @ 3 GHz

Model	Description	Panel Mount	Nut Driver Bit
DCJ-JR	Jack to Jack	Yes	NDT-DIN
BCJ-DCJ	BNC Jack to DIN1.0/2.3 Jack	Yes	N/A
BPC-DCJ	BNC Plug to DIN Jack	No	N/A

• Standard package (20 pcs)

- Return loss: 26.4 dB or greater up to 3 GHz.

Note: Nut driver bit NDT-DIN is required for DCJ-JR

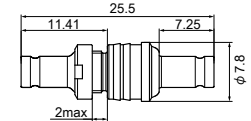

DCJ-JR

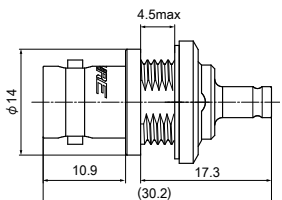

BCJ-DCJ

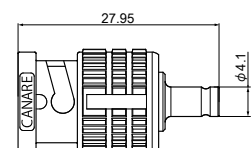

BPC-DCJ

<Panel Hole Dim.>

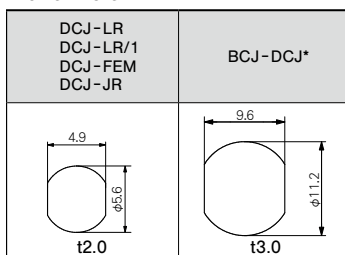

<PCB Hole Dim.>

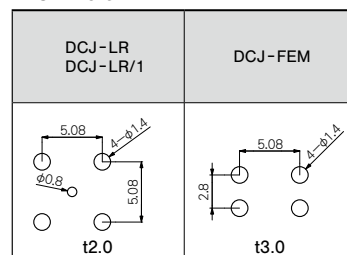

*BCJ-DCJ accepts insulation bushing IU-7/16. See page 24 for the panel hole with IU-7/16.

■ Nut Driver Bit

Model	Description
NDT-DIN	6.35mm (1/4") hex shank



NDT-DIN*

* Torque driver not included

Connectors

12G-SDI 75Ω Micro-miniature Coaxial Connectors

75Ω Micro-miniature Coaxial Connectors

Website



Canare's exclusive micro miniature connectors, KC series : specially designed for 4K/8K UHD equipment. Our PCB mount solutions provide flexible layout and reliable connectivity on 12G-SDI signal path. Products are 12GHz verified and guaranteed SMPTE ST2082-1.

PCB Mount Receptacles **12G-SDI**

Model	Description
KCM-PC	Straight
KCM-LR	Right Angle

• Standard package (20 pcs)



KCM-PC



KCM-LR

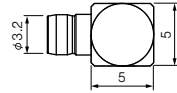

KC to BNC Conversion Adapter **12G-SDI**

Model	Description	Nut Driver Bit
BCJ-KCM	Rear Mount, Hex Nut	—
BCJ-FKCM	Front Mount, Grooved Nut	NDT-7/16

• Standard package (20 pcs)

Note: BCJ-FKCM requires the nut driver bit NDT-7/16 for installation and removal. Contact for the details.

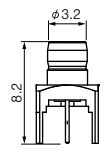

KCM-PC

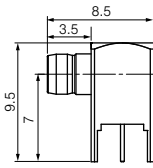

KCM-LR



BCJ-KCM



BCJ-FKCM

Cable Assemblies **12G-SDI**

Model	Description	
	Plug A	Plug B
KC1.2R-****-S	Straight	Straight
KC1.2R-****-L	Right Angle	Right Angle
KC1.2R-****-SL	Straight	Right Angle

Jacket: FEP (blue)

****: cable length (see below)



KC1.2R-****-S



KC1.2R-****-L

<Ordering Information>

KC1.2R - 0015 - S	
Length	Plug Type
0015 150 mm	S Straight
0020 200 mm	L Right Angle
0030 300 mm	SL Straight to Right Angle

Custom length available. Contact for the details.

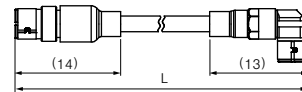

KC1.2R-****-SL

- DC to 12 GHz; meets the SMPTE 2082-1 return loss requirements.
Return loss : 26 dB @ 1.5 GHz, 20 dB @ 3 GHz,
15 dB @ 6 GHz, 10 dB @ 12 GHz
- Snap-on engaging
- Durable design; beneficial for maintenance.
- Temperature range : -25 to 85 degree C
- The best flexibility on PCB design

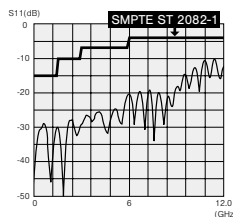

Return Loss
Interface to Termination
(reference)

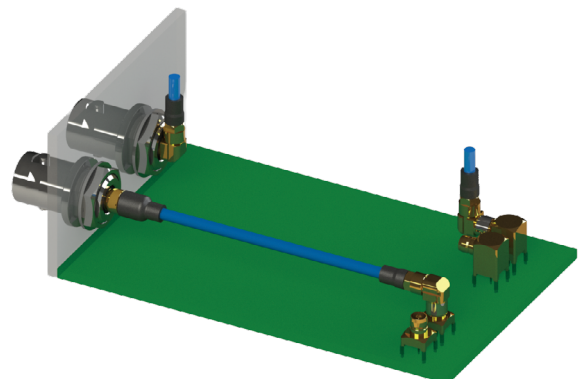

<Example of Use>

4K-DIN Coax Connectors

Canare unique “4K-DIN” allows you to connect or disconnect 4 of 3G-SDI signals in one easy step.

■ Crimp Plugs Return Loss: 20 dB @ 3 GHz

Model	Suitable Cable	Die Set	Description
MDM-V4C25HW	V4-2.5CHW	TCD-D253F	Male
MDF-V4C25HW	V4-2.5CHW	TCD-D253F	Female

■ Flush-mount Receptacle Return Loss: 20 dB @ 3 GHz

Model	Description
MDF-V4JRU	Jack to Jack

- 75Ω 4-channel coax connector with push-pull locking mechanism.
- Compact, solid, and lightweight nylon resin (PA 66) body
- Return loss: 20 dB @ 3 GHz
- MDF-V4JRU accepts MDM-V4C25HW and also DIN 1.0/2.3 plugs.

* Replacement crimp units also available:
DCP-C25HW-ML for MDM
DCJ-C25HW-ML for MDF

<Connection Example>

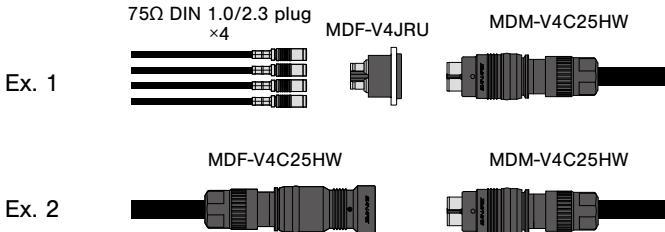

Be sure to use Canare Crimp Tool

75Ω Multi-pin Coax Connectors

Handles five 75Ω coaxial connections.

Model	Suitable Cable	Die Set	Description
MCM-V5C3	V5-3C	TCD-35CA	Plug
MCF-V5C3	V5-3C, L-3C2V, L-3C2VS	TCD-35CA	Receptacle

Model	Description
DCM01	Dust Cap for MCM-V5C3
DCF01	Dust Cap for MCF-V5C3

- 1.2 or less VSWR up to 1.5 GHz.
- Crimp system ensures quick and reliable installation.

* Replacement unit also available. MCM-V5C3: BN9078A MCF-V5C3: BN9079B

Be sure to use Canare Crimp Tool

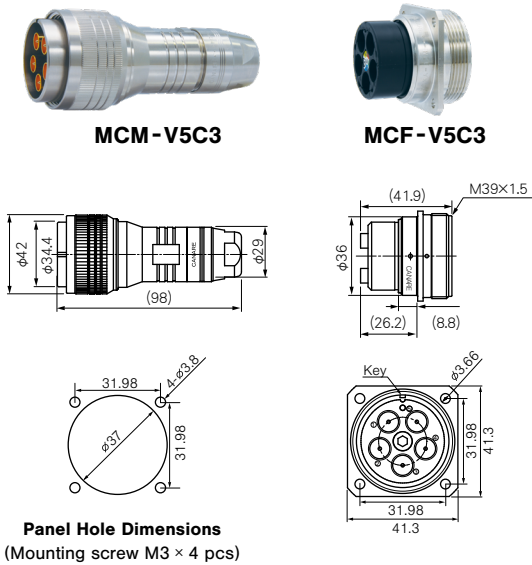

Panel Hole Dimensions
(Mounting screw M3 × 4 pcs)



Replacement Unit **BN9078A**

Replacement Unit **BN9079B**



Website

Technical Trend

IP Connectivity Products

Fiber-Optic Systems

Connectors

Cables



Website

Panels & Patchbays

Multichannel Systems

Cable Assemblies

Connectors

75Ω Triaxial Connectors

75Ω Triaxial Connectors

Website



Canare CC series cover global triaxial interconnection. CC-F series are ideal for interconnecting European triax system and CC-K series for American triax system.

- True 75Ω, DC 1.5 GHz; ≥20 dB return loss (≤1.2 VSWR)
- Push-lock mechanism
- Reliable crimp system
- Rugged and durable construction

■ CC-F Series : European preferred type

Model	Description	Suitable Cable		Boot/Cap	Center contact	Sleeve A	Sleeve B	Crimp Tool
		Canare	Others					
CCF5-JFC	Crimp type, Female cable mount	L-5CFTX	Belden : 7783A Klotz : TRIAX8 Fujikura : 4.8/1.0 EFTXF	CB31	BN9194	BN7120	BN7121	TC-1 + TCD-65C
CCM5-PFC	Crimp type, Male cable mount			CB32	BN1135			
CCF5-JFRC	Crimp type, Female panel mount			DCF02	BN9194			
CCM5-PFRC	Crimp type, Male panel mount			DCM02	BN1135			
CCF7-JFC	Crimp type, Female cable mount	L-7CFTX	Belden : 7784AS Klotz : TRIAX11 Fujikura : SUPERFLEX11	CB31	BN9182A	BN7113	BN7114	TC-2 + TCD-96C
CCM7-PFC	Crimp type, Male cable mount			CB32	BN1131			
CCF7-JFRC	Crimp type, Female panel mount			DCF02	BN9182A			
CCM7-PFRC	Crimp type, Male panel mount			DCM02	BN1131			

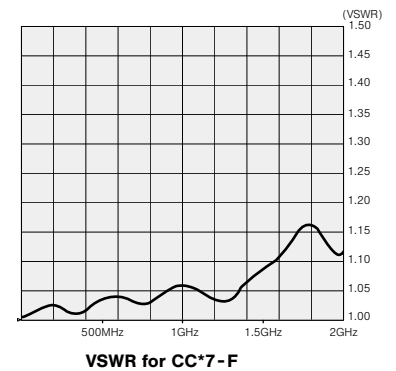
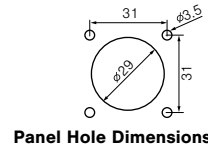
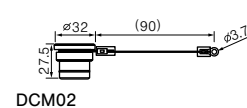
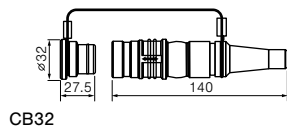
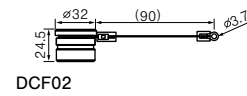
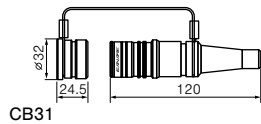
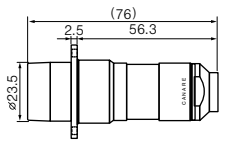
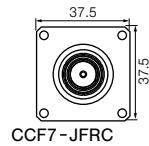
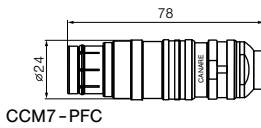
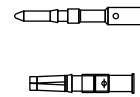
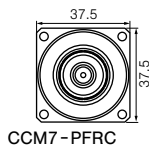
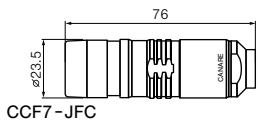

■ CC-K Series : U.S. preferred type

Model	Description	Suitable Cable		Retrofit Kit	Boot/Cap	Crimp Tool
		Canare	Others			
CCF4-JK	Crimp type, Female cable mount	L-4CFTX	Belden : 1856A, 1857A, 9267 Gepeco : LVT61859, VT61859	BN9127B	CB23	TC-1 + TCD-316C
CCM4-PK	Crimp type, Male cable mount			BN9128C	CB22	
CCF4-JKR	Crimp type, Female panel mount			BN9127B	DCM02	
CCM4-PKR	Crimp type, Male panel mount			BN9128C	DCM03	

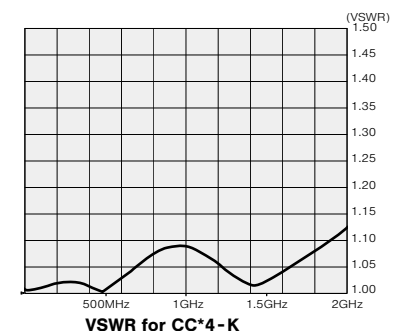
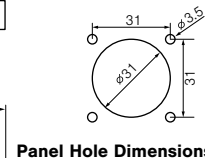
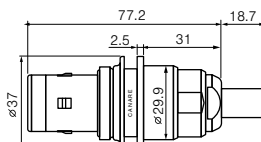
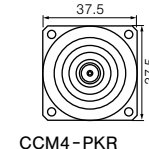
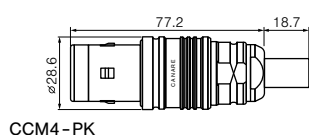
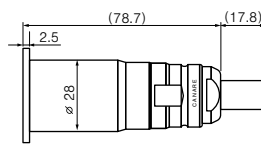
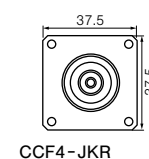
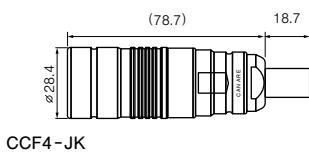

RCA Pin Connectors

■ Crimp Plugs

Model	Suitable Cable		Center Pin	Sleeve	Boot	Die Set
	Canare	Others				
RCAP - C25F	L-2.5CFB	1855A, 8218, 1417B, 1418B	B11014E	BN7029C	—	TCD-35CA
RCAP - C25HD	L-2.5CHD	—	B11015E	BN7129	—	TCD-35CA
RCAP - C3A	L-3C2VS, L-3C2V, V*-3C	—	B11014E	BN7003A	CB24	TCD-35CA
RCAP - C3GS	GS-6	—	BN1093	BN7079	CB25	TCD-35D
RCAP - C3F	L-3CFB, V*-3CFB	—	B11015E	BN7003A	CB24	TCD-35CA
RCAP - C42	—	1505F	B11016E	BN7011	—	TCD-31C
RCAP - C4A	LV-61S	8241, 8279, RG-59B/U	B11015E	BN7015A	CB25	TCD-4CA, TCD-451CA
RCAP - C4F	L-4CFB, V*-4CFB	1505A, 1505ANH, 8212, 8241F, 9167, 9259, 9659	B11016E	BN7015A	CB25	TCD-4CA, TCD-451CA
RCAP - C53	L-4.5CHD	1694A, 9066, 9116, 9118, 9248	B11020D	BN7016	CB26	TCD-35CA
RCAP - C5A	L-5C2VS, L-5C2V, V*-5C	—	B11016E	BN7016	CB26	TCD-35CA
RCAP - C5F	L-5CFB, V*-5CFB	—	B11020D	B75004A	CB26	TCD-5CF, TCD-55FA
RCAP - C77	LV-77S	8281F	B11016E	B75004A	CB26	TCD-5CF, TCD-55FA

- Standard package (20pcs/100pcs)
- Canare crimp design ensures quick and reliable installation.
- The crimp tool for the RCAP-C can be used for the Canare crimp BNC plugs as well, thus saving on extra equipment.

Be sure to use Canare Crimp Tool

■ Solder Plugs

Model	Description
F-09	Plug
F-10	Plug (long sleeve)

- Standard package (10 pcs)
- Robust metal shell
- Comfortable grip
- Cable O.D. up to 6.0 mm.

■ Standoff Receptacle

Model	Description
RJ-JR	Jack to Jack

- Standard package: 20 pcs by insulation color
- Insulation color is available in 5 colors (red, green, blue, yellow, white).
- VSWR 1.2 @ 100 MHz

■ Flush-mount Receptacles

Model	Description	Flange Type	Insulator Color
RJ-RU	RCA - Solder	ITT XLR-F77	
RJ-RUD		Neutrik D	RED GRN BLU YEL WHT
RJ-RUDB		Neutrik D (Black)	
RJ-JRU	RCA - RCA	ITT XLR-F77	
RJ-JRUD		Neutrik D	RED BLU YEL WHT
RJ-JRUDB		Neutrik D (Black)	
RJ-BCJRU	RCA - BNC	ITT XLR-F77	RED GRN BLU YEL WHT
RJ-BCJRUD		Neutrik D	
RJ-BCJRUDB		Neutrik D (Black)	RED BLU YEL WHT

- Standard package: 20 pcs by insulation color
- Three types of flanges are available.
- Insulation color is available in 5 colors (red, green, blue, yellow, white).
RJ-BCJRUDB, RJ-JRUD is 4 colors (red, blue, yellow, white)
- VSWR 1.2 @ 100 MHz

<Panel Hole Dimensions>

RJ-JR (*)	ITT XLR-F77 Flange	Neutrik D Flange

(*) RJ-JR accepts insulation bushing IU-7/16; in this case, panel hole for IU-7/16 should be adopted (see page 24)

Website

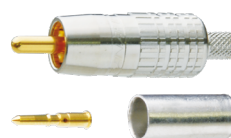

RCAP - C3A



F-09

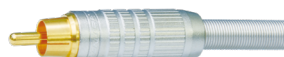

F-10



RJ - JR

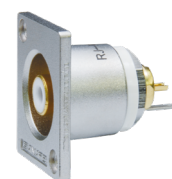

RJ - RU



RJ - JRUD

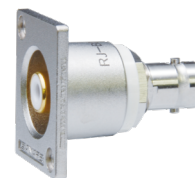

RJ - BCJRU

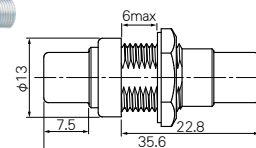

RJ - JR

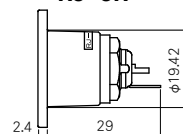

RJ - RU

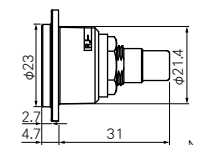

RJ - JRUD

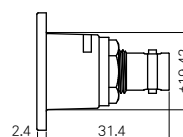

RJ - BCJRU

Technical Trend

IP Connectivity Products

Fiber-Optic Systems

Connectors

Cables

Panels & Patchbays

Multichannel Systems

Cable Assemblies

Connectors

F Connectors

F Connectors

This type is used in such applications as home television receivers for cable television (CATV) systems.

Website



■ Crimp Plugs

Model	Suitable Cable		Center Pin	Sleeve	Boot	Die Set
	Canare	Others				
FP-C25HD	L-2.5CHD	—	BN1003B	BN7129	—	TCD-35CA
FP-C3	L-3C2VS, L-3C2V, V*-3C	—	BN1002B	BN7003A	CB24	TCD-35CA
FP-C31	L-3C2W	—	BN1002B	BN7011	CB25	TCD-31C
FP-C3F	L-3CFB, V*-3CFB	—	BN1003B	BN7003A	CB24	TCD-35CA
FP-C4	LV-61S	8241, 8279, RG-59B/U	BN1003B	BN7015A	CB25	TCD-4CA, TCD-451CA
FP-C4F	L-4CFB, V*-4CFB	1505A, 1505ANH, 8212, 8241F, 9167, 9259, 9659	BN1004B	BN7015A	CB25	TCD-4CA, TCD-451CA
FP-C5	L-5C2VS, L-5C2V, V*-5C	—	BN1004B	BN7016	CB26	TCD-35CA
FP-C52	L-5C2W	—	BN1004B	BN7014	—	TCD-451CA
FP-C53A	L-4.5CHD	1694A, 9066, 9116, 9118, 9248	BN1005B	BN7046	CB26	TCD-35CA
FP-C5F	L-5CFB, V*-5CFB	—	BN1005B	B75004A	CB26	TCD-5CF, TCD-55FA
FP-C71A	—	7731A, 9064, 9292, 1617A, 9011	BN1041A	BN7021A	—	TCD-7CA
FP-C7FA	L-7CFB	—	BN1030A	BN7021A	—	TCD-7CA

• Standard package (20pcs/100pcs)

- Lock mechanism improves reliability by preventing shifting or detaching of the center pin.
- The tools and cable stripper can be used for the Canare crimp BNC plugs as well, thus saving on extra equipment.
- VSWR of 1.1 or less up to 2 GHz.
- Designed for indoor use.

Be sure to use Canare Crimp Tool



FP-C4

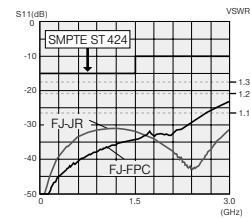

Fig.1 Return loss for FJ-FPC and FJ-JR

■ Standoff Receptacle

Model	Description
FJ-JR	Jack to Jack
FJ-FPC	PC Board Straight Mount

• Standard package (20pcs/100pcs)

- VSWR of 1.1 or less up to 2 GHz. <Fig. 1>
- Accept insulation bushing IU-7/16. See page 24 for more information.

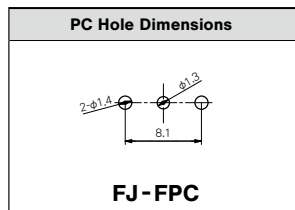
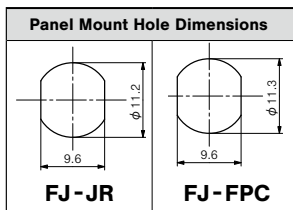

FJ-JR



FJ-FPC



FJ-JRU

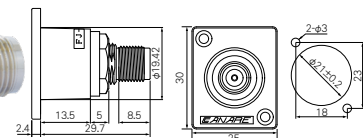

FJ-JRU

■ Flush-mount Receptacles

Model	Description	Flange Type
FJ-JRU	Jack to Jack	ITT XLR-F77
FJ-JRUD		Neutrik D
FJ-JRUDB		Neutrik D (Black)

• Standard package (20pcs)

- Three types of flanges are available.



FJ-JRUD

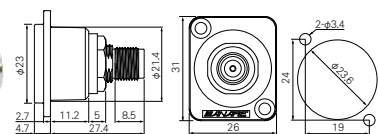

FJ-JRUD

Phone Plugs

Website



Featuring a properly cable clamp system ensures long life reliability.

■ 3.5mm Mini Phone Plug

F - 11	F - 12	F - 12SA
Description		
2 Conductor 3.5mm mini phone plug	3 Conductor 3.5mm mini phone plug	3 Conductor 3.5mm mini phone plug *Smaller shell version of F-12
Nickel contacts, Nickel shell φ 6.0 max (w/o spring : φ 7.5 max)	Nickel contacts, Nickel shell φ 6.0max (w/o spring : φ 7.5 max)	Nickel contacts, Nickel shell φ 5.0max (w/o spring : φ 6.7 max)

• Standard package (10pcs)

■ 1/4" Phone Plug

F - 15	F - 15L	F - 16
Description		
2 Conductor 1/4" phone plug	2 Conductor 1/4" phone plug *Right-angle Type	3 Conductor 1/4" phone plug
Nickel contacts, Nickel shell φ 6.0max (w/o spring : φ 7.5 max)	Nickel contacts, Nickel shell φ 6.0max (w/o spring : φ 7.5 max)	Nickel contacts, Nickel shell φ 6.0max (w/o spring : φ 7.5 max)

• Standard package (10pcs)

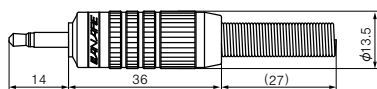

F - 11

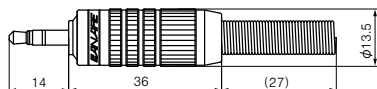

F - 12

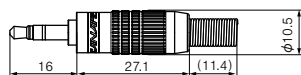

F - 12SA

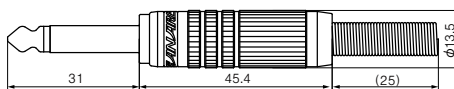

F - 15

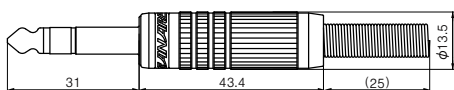

F - 16

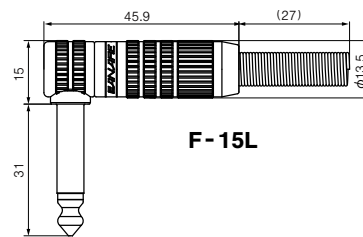

F - 15L

Canare's durable design

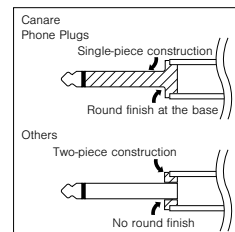

Technical Trend

IP Connectivity Products

Fiber-Optic Systems

Connectors

Cables

Panels & Patchbays

Multichannel Systems

Cable Assemblies

Connectors

50Ω BNC Connectors

50Ω BNC Crimp Plugs

VSWR of 1.1 or less up to 2 GHz, 1.2 or less up to 4 GHz.

■ Straight

Model	Suitable Cable	Center Pin	Sleeve	Boot	Die Set
BP-C3	L-3D2V, 3D-2V	BN1023A	BN7003A	CB03	TCD-35D
BP-C31	L-3D2W, 3D-2W	BN1023A	BN7011	CB04	TCD-3151D
BP-C4	RG-58C/U, RG-58A/U	BN1024A	BN7030A	CB03	TCD-35D
BP-C5	L-5D2V, 5D-2V	BN1025B	BN7016	CB05A	TCD-35D
BP-C51	L-5D2W, 5D-2W	BN1025B	BN7002	—	TCD-3151D
BP-C5FA	L-5DFB, 5D-FB	BN1016C	B75004A	CB05A	TCD-35DF TCD-55FA
BP-C51F	L-5DFBW-PE	BN1016C	BN7002	—	

• Standard package (20pcs)

■ Right Angle

Model	Suitable Cable	Center Pin	Sleeve	Die Set
BP-LC31	L-3D2W, 3D-2W	BN1023A	BN7011	TCD-3151D
BP-LC51	L-5D2W, 5D-2W	BN1025B	BN7002	

• Standard package (20pcs)

- Lock mechanism used on insulation improves reliability by preventing shifting or detaching of the contact pins.
- Elongated body design for straight type enables easy attachment and removal.
- Gold plating on the contact pin prevents deterioration, even after years of use.
- Use of crimping to attach the connectors ensures quick, reliable installation.

Be sure to use Canare Crimp Tool



BP-C5



BP-LC31

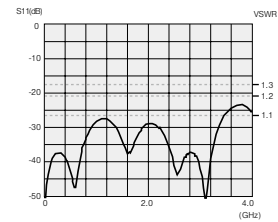

Return loss for BP-C31



BJ-JR

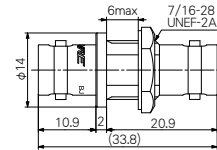

BJ-JR

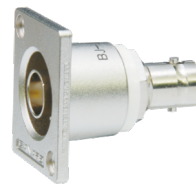

BJ-JRU

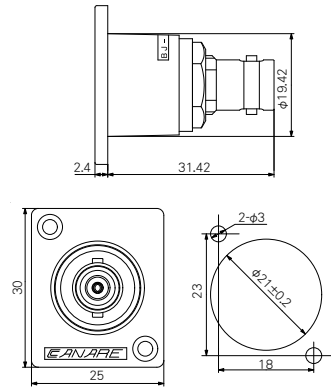

BJ-JRU

50Ω BNC Receptacles

■ Standoff

Model	Description
BJ-JR	Jack to Jack

• Standard package (20pcs)

- Mounting hole size is same as that for BCJ-R/1 connector.

■ Flush-mount Receptacles

Model	Description	Flange Type
BJ-JRU	Jack to Jack	ITT XLR-F77
BJ-JRUD		Neutrik D

• Standard package (20pcs)

- Two types of flanges are available.
- Flush-mount receptacle prevents damage on the jack.

50Ω BNC Extension Adapter

Model	Description
BJ-J	Jack to Jack

• Standard package (20pcs)

- VSWR of 1.1 or less up to 4 GHz.



BJ-J

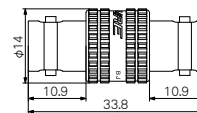

BJ-J

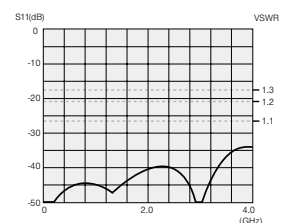

Return loss for BJ-J

50Ω TNC Crimp Plugs

■ Straight

Model	Suitable Cable	Boot	Die Set
TNP-C3	L-3D2V, 3D-2V	CB03	TCD-35D
TNP-C31	L-3D2W, 3D-2W	CB04	TCD-3151D
TNP-C4	RG-58C/U, RG-58A/U	CB03	TCD-35D
TNP-C5	L-5D2V, 5D-2V	CB05A	
TNP-C51	L-5D2W, 5D-2W	—	TCD-3151D
TNP-C5F	L-5DFB, 5D-FB	CB05A	TCD-35DF TCD-55FA

• Standard package (20pcs)

- VSWR of 1.1 or less up to 2 GHz, 1.2 or less up to 4 GHz.
- Canare crimp design ensures quick and reliable installation

Be sure to use Canare Crimp Tool

Website



TNP-C3

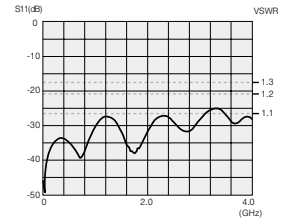

Return loss for TNP-C3

Technical Trend

IP Connectivity Products

Fiber-Optic Systems

50Ω N Crimp Plugs

■ Straight

Model	Suitable Cable	Boot	Die Set
NP-C31	L-3D2W, 3D-2W	CB04	TCD-3151D
NP-C51	L-5D2W, 5D-2W	—	
NP-C5F	L-5DFB, 5D-FB	CB05A	TCD-35DF TCD-55FA
NP-C51F	L-5DFBW-PE	—	TCD-55FA

• Standard package (20pcs)

■ Straight Jack

Model	Suitable Cable	Boot	Die Set
NJ-C5F	L-5DFB, 5D-FB	CB05A	TCD-35DF TCD-55FA

• Standard package (20pcs)

- VSWR of 1.1 or less up to 2 GHz, 1.2 or less up to 4 GHz.
- Canare crimp design ensures quick and reliable installation

Be sure to use Canare Crimp Tool

Website



NP-C51

Connectors

Cables

50Ω SMA Crimp Plugs

■ Straight

Model	Suitable Cable	Die Set
SMAP-C1	1.5D-QEW	TCD-1DB
SMAP-C31A	L-3D2W, 3D-2W	TCD-3151D
SMAP-C3F	L-3DFB	TCD-35DF
SMAP-C51	L-5D2W, 5D-2W	TCD-3151D
SMAP-C5F	L-5DFB, 5D-FB	TCD-35DF, TCD-55FA

• Standard package (20pcs)

■ Straight Jack

Model	Suitable Cable	Die Set
SMAJ-C3F	L-3DFB	TCD-35DF
SMAJ-C51	L-5D2W, 5D-2W	TCD-3151D
SMAJ-C5F	L-5DFB, 5D-FB	TCD-35DF, TCD-55FA

• Standard package (20pcs)

- VSWR of 1.1 or less up to 2 GHz, 1.2 or less up to 4 GHz. (SMAP-C1: VSWR of 1.2 or less up to 2 GHz)
- Canare crimp design ensures quick and reliable installation (SMAP-C1 has solder center contact)

Be sure to use Canare Crimp Tool

Website



SMAP-C1

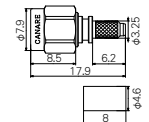

SMAP-C1



SMAP-C31A



SMAJ-C3F

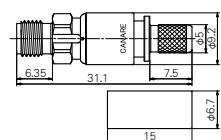

SMAJ-C3F

Panels & Patchbays

Multichannel Systems

Cable Assemblies

Connectors

Cable Stripper, Crimp Tools

Coaxial Cable Stripper

Three internal circular steel blades perform precise, extremely clean and easy stripping.

Model	Preset to
TS100E	LV-77S-L-5CFB, V*-5CFB, V*-5C, LV-61S-L-4CFB, V*-3C
TS100H	L-2.5CHD-L-2.5CHLT, L-3.3CUHD-L-3C-AHD, L-3CFB-L-3C2V-L-3C2VS, L-5CFB, L-4CFB
TS100U	L-2.5CHD, 1855A, 1505A, 1694A

- For most Canare BNC, DIN, RCA and F crimp plugs.
 - Rotary knob to select 5 different cable setups.
 - Make your own cable setting within cable O.D. 4mm~11mm
 - Hex wrench is attached on the lid top for quick adjustment.
 - One replacement blade included, and also sold separately.
- Replacement blade: TSC (1pc)

Note: The stripping quality of coaxial cables may be affected by their construction, particularly in the following cases:

1. Harder jackets
2. Softer insulation
3. Multilayer shielding

These factors can result in suboptimal stripping conditions.

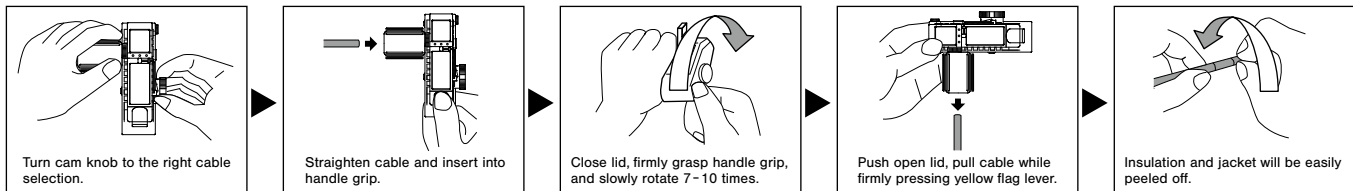

TS100E

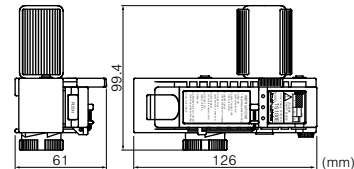

Website

Crimp Tools

Canare crimp tool offers reliable high-quality crimping performance in an easy-to-use design.

Die Sets

Model	Pin Crimp		Sleeve Crimp		Model
	#1 (mm)	#2 (mm)	#3 (mm)	#4 (mm)	
TC-D-1DB	—	—	3.94	—	TC-1
TC-D-31C	1.37	—	6.75	—	TC-1
TC-D-3151D	1.92	—	8.36	6.75	TC-1
TC-D-316C	1.35	—	9.4	6.75	TC-1
TC-D-35CA	1.35	—	7.6	5.85	TC-1
TC-D-35D	1.92	—	7.6	5.85	TC-1
TC-D-35DF	1.92	2.1	8.05	5.82	TC-1
TC-D-4CA	1.35	—	6.48	—	TC-1
TC-D-451CA	1.35	—	8.36	6.4	TC-1
TC-D-5CF	1.31	—	8.05	—	TC-1
TC-D-5HD	1.87	—	8.05	—	TC-1
TC-D-55FA	1.35	2.1	8.05	—	TC-1
TC-D-55UHD	1.62	—	8.05	—	TC-1
TC-D-57C	1.62	—	8.5	—	TC-1

Hand Crimp Tools

Die Sets

Model	Pin Crimp		Sleeve Crimp		Model
	#1 (mm)	#2 (mm)	#3 (mm)	#4 (mm)	
TC-D-65C	1.92	—	9.4	7.6	TC-1
TC-D-67HD	2.1	—	10.2	—	TC-1
TC-D-7CA	1.87	—	10.2	—	TC-1
TC-D-8HD	2.4	—	11.26	—	TC-2
TC-D-96C	1.92	—	11.26	9.4	TC-2
TC-D-D253F	1.1	—	5.1	5.85	TC-1
TC-D-D534F	1.27	—	7.55	6.4	TC-1

Hand Crimp Tools

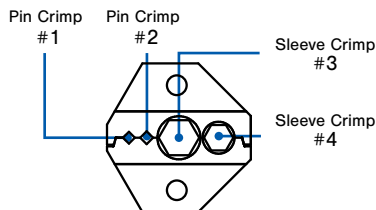

Website

Crimp Tools



Website

Tool Case

Accessories

Model	Description	Length
TB-2A	Tool case	—
BET-BNC	Extraction tool for BNC straight plug	300 mm
BET-MBNC	Extraction tool for MBNC-C series	300 mm
BET-HBNC	Extraction tool for HBCP-D25HDA, D25HWA, D33UHDA (Narrow Pitch Ready: 8mm)	300 mm
BET-DIN	Extraction tool for DCP-C series	300 mm
BET-D/H	Extraction tool for DCP-C, HBCP-D series & HBCP-DA series Narrow Pitch Ready: DCP-C: 11mm HBCP-D25HDA, D25HWA, D33UHDA: 10mm HBCP-D53A, D55UHD: 12mm	300 mm



TB-2A
(tools and connectors not included)

- Select the appropriate die set to suit the individual connector
- Hand crimp tool is required for die set, and sold separately
- Die set are interchangeable



TC-1



BET-BNC

BET-HBNC

BET-MBNC

BET-DIN

BET-D/H



Website

Extraction Tools

Crimp Connector Assembly Instructions

	<p>Confirm compatibility of the connector and cable prior to assembly.</p> <ol style="list-style-type: none"> Slide the crimp sleeve over the cable and strip the jacket, braided shield, and insulation of the coaxial cable as shown at left. <ul style="list-style-type: none"> For cables with stranded inner conductor, twist the strands in the same direction as plied after removing the insulation. For a crimp sleeve with steps, slip it over the cable from the stepped end, as in the diagram. If any metal foil shield is left on the cable, it may get stuck in the mouth of connector, making insertion impossible. Remove all stray strands and offcuts of the metal foil shield to avoid possible short circuiting. Make sure the inner conductor is free of all insulation debris and offcuts to ensure complete crimping.
	<ol style="list-style-type: none"> Place the center contact pin of the connector on the inner conductor of the cable and crimp the center contact pin at the correct position (without remaining a gap) as shown at left, using the specified crimp tool and die set. <ul style="list-style-type: none"> To confirm the crimping properly, measure the crimp height after removing burrs with a knife. If it is not within the ideal value range, adjust the crimp tool. Do not crimp the center contact pin at the stepped root end. Confirm the center contact pin is crimped straight to the inner conductor. If the center contact pin is slanted, align it gently.
	<ol style="list-style-type: none"> Hold the cable and push it into the connector body until the center contact is locked in place. You may feel a click sound when the center contact is locked. <ul style="list-style-type: none"> Pull the cable gently (less than 4.5 lbs or 19.6 N) to confirm that is locked.
	<ol style="list-style-type: none"> Slide crimp sleeve up against connector body over the braided shield until it butts against the connector body. Center the die over the crimp sleeve and crimp in place, using the specified crimp tool and die set. <ul style="list-style-type: none"> Do not pull the cable while crimping is executed.

Adjusting Crimp Tool

1. Measuring Crimping height
 Crimp height is measured after the crimp is made. As shown in the figure, the sum of the measured values for both directions is divided by two to arrive at the crimp height. The ideal value range for the BCP-A3 connector, for example, is 1.4 mm to 1.5 mm. When this value is lower (overcrimping occurs) than the recommended crimp height, the crimp becomes very hard. A value higher (undercrimping occurs) than the recommended value can result in increased electrical resistance and a physically weaker crimp. Either digital calipers or a micrometer should be used for measuring crimp height.

2. Measuring Frequency
 Crimp height is measured prior to commencing use of the crimp tool and always when changing the crimping die. After this, the crimp height is regularly measured after about each 1,000 crimps.

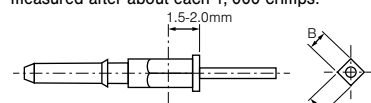

Crimp height value= (A+B) / 2

Refer to the separately included manual for the appropriate crimp height values for individual connectors.

3. Tool Measuring Procedures
 Crimp force increases and crimp height decreases when the tool's adjuster dial is turned in the direction of the 9. The dial is adjusted by first releasing it using a screw driver.



FAQ

Q Does it matter in which direction crimp sleeves are attached?

A For BCP-A3-use and other non-stepped (straight type) crimp sleeves, it does not matter in which direction the crimp sleeve is attached. The attachment direction also does not matter for BCP-A5F-use and other specific-use types that have a chamfer (groove) at one end of the crimp sleeve. However, stepped crimp sleeves such as those for BCP-C1, etc. are directional and must be attached in the direction shown in the diagram below, with the cable threaded through the sleeve starting from the end with the step (that is, the end with smaller-diameter hole).



Q What should be done with a metal foil shield?

A Strip the metal foil shield to the root of the braided shield (to the edge of the jacket). If any metal foil shield is left on the cable, it may get stuck in the mouth of connector, making insertion impossible.

Q Why do some BNC plugs made by other companies have a sharp point at the tip of the central contact? Are these compatible with Canare's BNC receptacles?

A The central contact is pointed in conformance with the JIS standard for 50Ω BNC connectors. The central contacts on Canare's connectors conform to the MIL standard, and therefore are not pointed. These two different shapes simply offer different ways to guide the plug into the female receptacle and have no direct effect on contact quality.

The actual contact surfaces on Canare's BNC connectors are designed in conformance with JIS standards and therefore pose no compatibility problems.

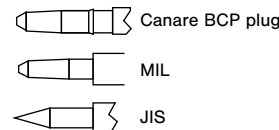

Q Is it possible to use cables not listed in the connector compatibility table as long as they are close to the dimensions of those listed?

A No. While connection may be possible, performance may be adversely affected. Even if the connection appears to work, factors such as electrical instability, weak cable contact strength and others may cause problems during actual use. Therefore, it is necessary to test and evaluate whether it is actually possible to use the configuration in question. Particular caution should be used when crimping is involved.

Q What is meant by "cable contact strength"?

A Cable contact strength refers to the maximum load borne by the cable when exerting tensile force to remove it from the connector. For Canare products, "cable contact strength" refers to the contact strength of a cable's outer conductor, not including the pull-out strength of the central contact or the contact strength of the inner conductor.

Q What is the approximate insertion loss associated with connectors?

A The value varies depending on the connector, but for BNC plugs, the value is approximately 0.1 dB per plug (DC-2 GHz).

Connectors

Crimp Tools

Cables to Connector Cross-Reference

■ BNC, Slim BNC, F, RCA

See page 39-40, for 50Ω cables and connectors.
See page 42, for more information about the crimp height.
These tables include cables of other brands such as Belden, Draka, and Geppo.

Cable	BNC			Slim BNC MBCP-C	F FP-C	RCA RCAP-C	Multi-pin MCM/MCF	Suitable Die Set	Crimp Height
	BCP-D/B	BCP-A/C	BCP-L*						
L-1.5C2VS/V*-1.5C		BCP-C1						TCD-1DB	N/A (solder pin)
1.5C-2V									1.40 - 1.47
L-2.5C2V		BCP-A25							
L-2.5CFB		BCP-A25F	BCP-LD25HD	MBCP-C25F		RCAP-C25F		TCD-35CA	1.40 - 1.50
1855A	BCP-B26								
1855P									
L-2.5CHD/L-2.5CHLT	BCP-B25HD		BCP-LD25HD		FP-C25HD	RCAP-C25HD			
VDM230									
1855ENH	BCP-B28								
HD PRO 0.6/2.8 AF									
L-2.5CHWS	BCP-B25HW		BCP-LD25HW						
V4-2.5CHW									
L-3C2V/L-3C2VS		BCP-A3					MC*-V5C3	TCD-35CA	
V3-3C/V4-3C		BCP-A3	BCP-LC3		FP-C3	RCAP-C3A			
V5-3C		BCP-VA3					MC*-V5C3		
L-3CFB	BCP-B3F	BCP-A3F	BCP-LC3F	MBCP-C3F	FP-C3F	RCAP-C3F			
V*-3CFB									
L-3C-AHD		BCP-A3AHD							
L-3.3CUHD	BCP-D33UHD		BCP-LD33UHD						
L-3.3CUHWS	BCP-D33UHW							TCD-451CA	
1695A									
VSD2001TS		BCP-A55						TCD-35CA	
L-3C2W		BCP-A31			FP-C31			TCD-31C	
L-3CFW	BCP-B31F								
V*-3CFW									
LV-61S		BCP-A4		MBCP-C4	FP-C4	RCAP-C4A		TCD-4CA or TCD-451CA	1.40 - 1.50
RG-59B/U									
L-4CFB/V*-4CFB				MBCP-C4F	FP-C4F	RCAP-C4F			
1505A, 1505ANH	BCP-B4F	BCP-A4F							
HD PRO 0.8/3.7 AF									
VPM2000									
L-4CHD									
1505F		BCP-A42				RCAP-C42		TCD-31C	
L-4.5CHD	BCP-B53		BCP-LD53	MBCP-C53	FP-C53A	RCAP-C53			
1694A									
HD PRO 1.0/4.8 AF	BCP-B56								
L-4.5CHWS	BCP-B45HW							TCD-35CA	
L-5C2V/L-5C2VS		BCP-A5	BCP-LC5		FP-C5	RCAP-C5A			
V*-5C		BCP-A5							
LV-77S		BCP-VA5							
L-5CFB	BCP-B5F	BCP-A5F	BCP-LC5F	MBCP-C5F	FP-C5F	RCAP-C5F		TCD-5CF or TCD-55FA excluding BCP-A5F (*1)	
V*-5CFB		(*1)							
L-5CFW	BCP-B51F								
V*-5CFW									
8281F		BCP-A77				RCAP-C77			
L-5C2W		BCP-A52			FP-C52			TCD-451CA	
L-5CHD		BCP-C5HD						TCD-5HD	1.90 - 2.00
L-5.5CUHD	BCP-D55UHD							TCD-55UHD	
L-5.5CUHWS	BCP-D55UHW								
4794R	BCP-D57							TCD-57C	1.62 - 1.72
L-6CHD		BCP-C6HD							
L-7CHD		BCP-C7HD						TCD-67HD	2.15 - 2.25
L-7CFB		BCP-C7FA			FP-C7FA				
7731A								TCD-7CA	1.90 - 2.00
9292		BCP-C71A			FP-C71A				
L-8CHD/L-8CUHD	BCP-D8UHD							TCD-8HD	2.44 - 2.54
GS-6						RCAP-C3GS		TCD-35D	2.01 - 2.20

*1: Suitable die set for BCP-A5F is TCD-35CA

■ Micro BNC, DIN1.0/2.3, 4K-DIN

Cable	Micro BNC	DIN	4K-DIN	Suitable Die Set	Crimp Height
L-2.5CHD/L-2.5CHLT	HBCP-D	DCP-C	MDM/MDF	TCD-D253F	1.08 - 1.16
1855A	HBCP-D25HDA	DCP-C25HD			
VDM230					
L-2.5CHWS	HBCP-D25HWA	DCP-C25HW	MD*-V4C25HW		
V4-2.5CHW					
L-3CFB		DCP-C3F			
L-3.3CUHD	HBCP-D33UHDA				
L-4CFB		DCP-C4F		TCD-D534F	1.25 - 1.33
1505A					
VPM2000					
L-4CHD		DCP-C53			
L-4.5CHD	HBCP-D53A				
1694A					
VSD2001					
L-5.5CUHD	HBCP-D55UHD			TCD-55UHD	1.62 - 1.72

■ Video Patch Plugs

Cable	Video Plug	Suitable Die Set	Crimp Height
L-2.5CHWS	VWP-C25HW MVP-C25HW	TCD-D253F	N/A (solder pin)
	MCVP-C25HW SVP-C25HW	TCD-D253F	1.08 - 1.16
LV-61S	VWP-C4A MVP-C4	TCD-4CA or TCD-451CA	N/A (solder pin)
RG-59B/U			

Be sure to use in the suitable combination of cable, connector, and die set

110Ω-75Ω Impedance Transformers



Technical Trend

IP Connectivity Products

Fiber-Optic Systems

Connectors

Cables

Panels & Patchbays

Multichannel Systems

Cable Assemblies

Passively convert AES/EBU digital audio signals from 110Ω/XLR3 output to a 75Ω BNC coaxial cable and then back again to a 110Ω/XLR3 input.

■ Adapter Type

Model	Description
BCJ-XJ-TRC	XLR3 (F) - BNC Jack
BCJ-XP-TRC	XLR3 (M) - BNC Jack
BCJ-XJ-A10TRC	XLR3 (F) - BNC Jack, 10dB Attenuation Pad

■ Panel Mount Type

Model	Description (Front - Back)	Flange Type
XJ3F-TRC-BCJ	XLR3 (F) - BNC Jack	ITT XLR-F77
XJ3M-TRC-BCJ	XLR3 (M) - BNC Jack	
BCJ-TRC-XP3F	BNC Jack - XLR (F)	
BCJ-TRC-XP3M	BNC Jack - XLR (M)	
XJ3F-A10TRC-BCJ	XLR3 (F) - BNC Jack, 10dB Attenuation Pad	
BCJ-A10TRC-XP3F	BNC Jack - XLR3 (F), 10dB Attenuation Pad	

- SMPTE 276M and AES3 transmission standards
- Coaxial transmission of 2 channel digital audio
- Allows longer cable runs than 110Ω twisted pair
- AES/EBU signal distribution using Canare 75Ω video patchbays



BCJ-XJ-TRC



BCJ-XP-TRC



BCJ-XJ-A10TRC



XJ3F-TRC-BCJ



BCJ-TRC-XP3M

BCJ-XJ-TRC / BCJ-XP-TRC

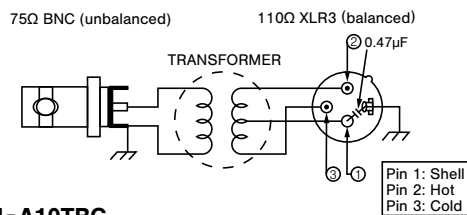

BCJ-XJ-A10TRC

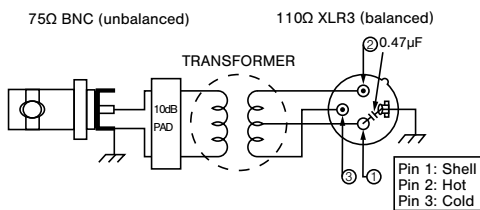

110Ω-75Ω Impedance Transformer: Input/Output Level Performance

AES/EBU Transmitter (V)	Transformer Out (V)
2.0	1.60
3.0	2.39
4.0	3.18
4.5	3.60
5.0	3.98
6.0	4.78
7.0	5.58
8.0	6.38
9.0	7.18
10.0	7.98

BCJ-XJ-TRC/BCJ-XP-TRC

AES/EBU Transmitter (V)	Transformer Out -10dB Pad (V)
2.0	0.50
3.0	0.75
4.0	1.01
4.5	1.13
5.0	1.26
6.0	1.51
7.0	1.76
8.0	2.02
9.0	2.27
10.0	2.52

BCJ-XJ-A10TRC

Panel Hole Dimensions

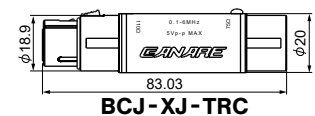
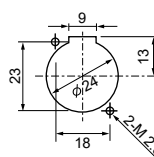

BCJ-XJ-TRC

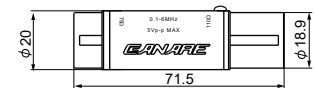

BCJ-XP-TRC

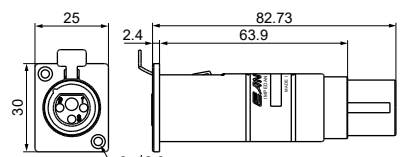

XJ3F-TRC-BCJ

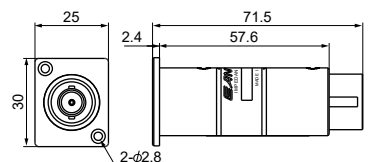

BCJ-TRC-XP3M