

Triaxial Connector Instruction Manual (CCM7-PFC/PFRC, CCF7-JFC/JFRC)

Thank you for purchasing a CANARE Product.

Note

- Before using this connector, please be sure to read this instruction manual for the correct use.
- Please keep this manual for future reference.

Warning

- Please follow this instruction manual exactly when terminating a cable.
- Please do not damage, forcefully bend or twist the cable.
- Anyone except electricians /electrical engineers are strictly prohibited from disassembling, repairing, or modifying this connector.
- Please be sure locking device is in place when connectors are mated.
- Appropriate protection should be taken if used outside.

Specification

- Model CCM7-PFC/ CCM7-PFRC/ CCF7-JFC/ CCF7-JFRC
- Applicable Cable CANARE : L-7CFTX-SC, BELDEN : 7764A
KLOTZ : TRIAX11, BEDEA : TRIAX11 SUPERFLEX
- Insulation Resistance 500MΩ or above at 500VDC
- Characteristic Impedance 75Ω

CANARE ELECTRIC CO. LTD.
<http://www.canare.co.jp/>



Product Lineup

CCM7-PFC

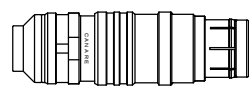

CCM7-PFRC

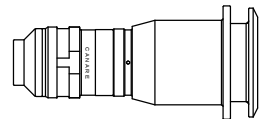

CCF7-JFC

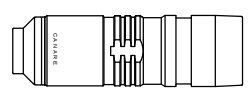

CCF7-JFRC

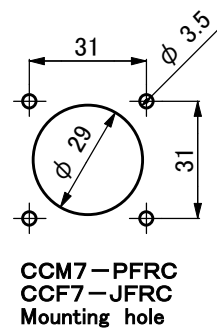
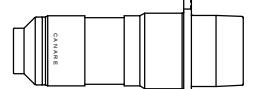

CB32

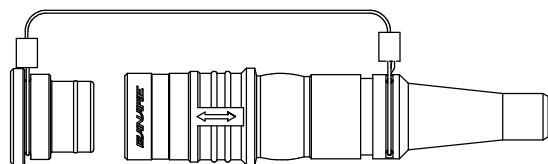

CB31

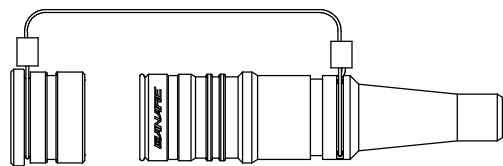

DCF02



Crimping TOOL : TC-2
Crimping Die : TCD-96C

DCM02

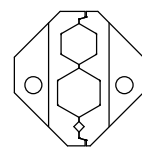

Parts

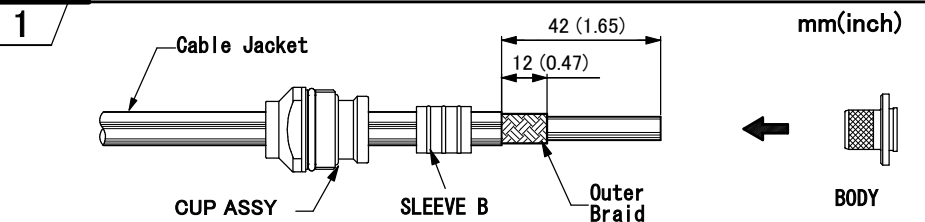
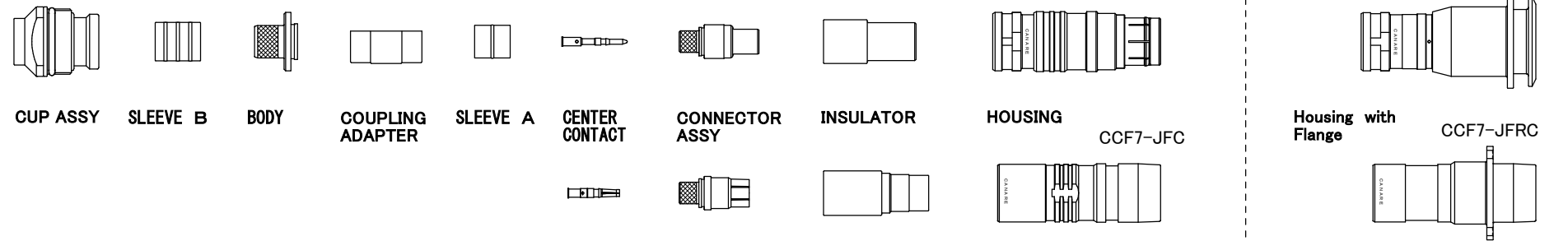

Tools / Wrenches : 19mm, 22mm / Crimping Tool & Die : TC-2 & TCD-96C

- ◆ Diagram references CCM7-PFC but instructions & dimensions can be used for all models.
- ◆ Slide CUP ASSY and SLEEVE B over the cable; remove Cable Jacket and Outer Braid of cable as shown in the diagram.
- *If you want to use cable boots CB31 or CB32, first you need to insert the boot onto the cable.
- *Remove completely the shavings and chips from Outer Braid.

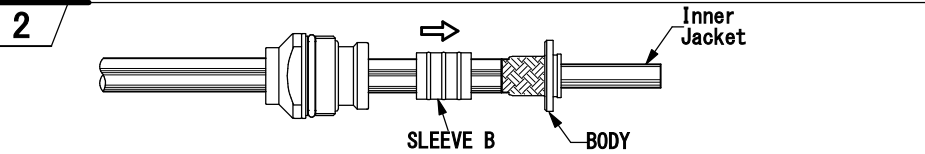

- ◆ Insert the BODY into the cable as shown in the the diagram (under the OuterBraid), and slide SLEEVE B over Outer Braid.
- (Note) DO NOT Crimp SLEEVE B yet. Cut excess braid to fit the BODY accordingly.

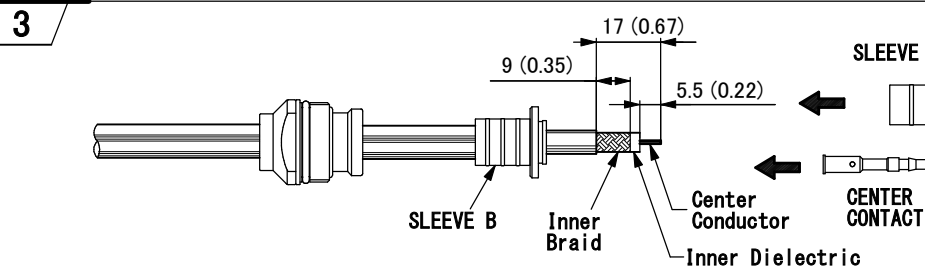

- ◆ Strip Inner Jacket, Inner Braid and Inner Dielectric, expose Center Conductor to the dimensions specified in the diagram.
- (Note 1) When Center Conductor is stranded, twist the strands in the same direction after cutting the insulation.
- (Note 2) Be careful not to nick or damage Center Conductor. Clean up any insulator scraps that may still remain attached to the Center Conductor.
- (Note 3) Clean up any braid scraps that may still remain attached to the Inner dielectric.
- ◆ Slide SLEEVE A onto the cable.

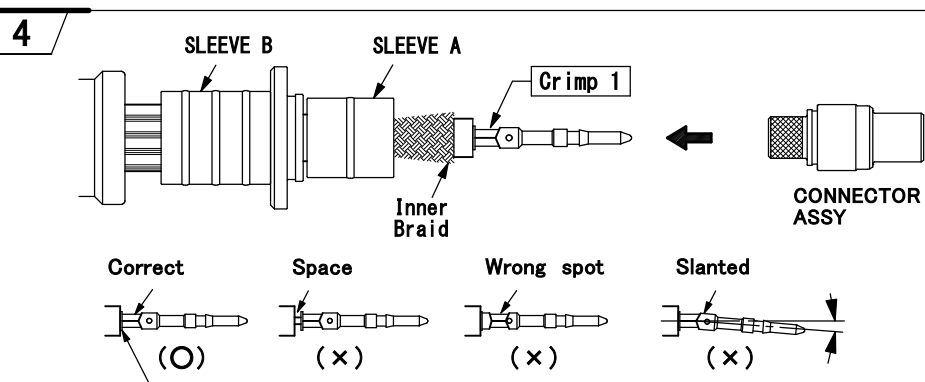

- ◆ Place CENTER CONTACT on Center Conductor. Using the TC-2 hand tool and TCD-96C die set, crimp CENTER CONTACT as shown in the diagram (→ Crimp 1). Do not leave a gap between rear of the pin (or socket) and cable Inner dielectric end. Also, do not crimp stepped part in the base of Center Contact as shown in the diagram.
- (Note) Measure crimp height to determine whether the CENTER CONTACT was crimped correctly. Be sure to remove splinters and remnants before measuring. The reference value of the crimp height should be 1.97-2.07mm(0.078-0.081 in). If greater or less than the reference value, adjust TC-2 hand tool. Confirm the center contact pin is crimped straight to the center conductor. If the center contact pin is slanted, align it gently.

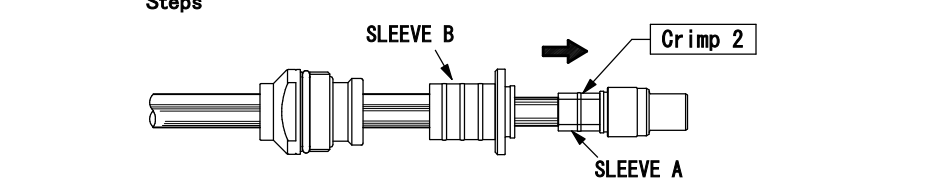

- ◆ Spread out the Inner Braid in order to insert the connector body smoothly. Insert the CONNECTOR ASSY to the cable until "snap" locked.
- (Note) Jamming the pin (or socket) may bend center conductor and damage Connector dielectric.
- ◆ Lightly tug cable (20N : 4.5lbf) to verify that pin (or socket) is properly seated in the CONNECTOR ASSY.
- ◆ Slide SLEEVE A up against CONNECTOR ASSY and place into the die. Complete assembly by crimping down on SLEEVE A to form hex (→ Crimp 2).

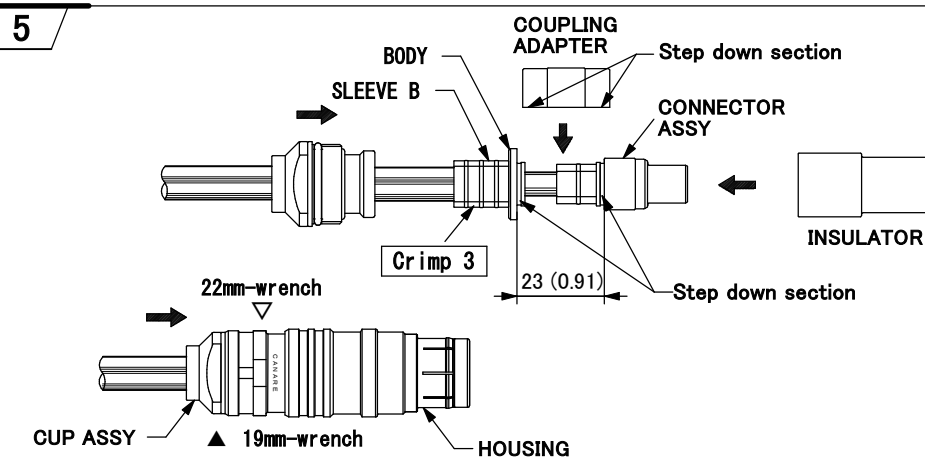

- ◆ Set COUPLING ADAPTER between BODY and CONNECTOR ASSY, snap in place. Make sure to fit into recesses of BODY and CONNECTOR ASSY.
- ◆ Slide SLEEVE B up against BODY and place in the die. Complete assembly by crimping down on SLEEVE B to form hex (→ Crimp 3).
- ◆ Slide INSULATOR over CONNECTOR ASSY and COUPLING ADAPTER see diaram.
- ◆ Drive HOUSING over completed assembly and tighten CUP ASSY and HOUSING using open wrenches size 19mm and 22mm at ▽ and ▽. * Apply torque force 5~6 N·m (44-52lb·in).

- ★ Finally, check the size of the assembled connector and status of the connection.
- ⚠ Note
- ★ Make sure shavings and chips from inside and outside braids do not enter inside the connector, as it may cause a short circuit.
- ★ When tightening the CUP ASSY, use only designated wrenches, and apply the torque specified.